

未注公差/General tolerances(mm)											0.1/10 ±2'		
0	>3	>6	>10	>18	>30	>50	>80	>120	>180	>250		>315	>400
~3	~6	~10	~18	~30	~50	~80	~120	~180	~250	~315	~400	~500	~2.50
±0.12	±0.18	±0.22	±0.26	±0.31	±0.37	±0.57	±0.80	±0.93	±1.05	±1.15	±1.60	±2.20	±2.50

A

B

C

D

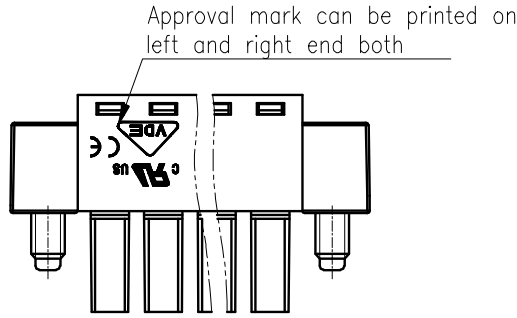
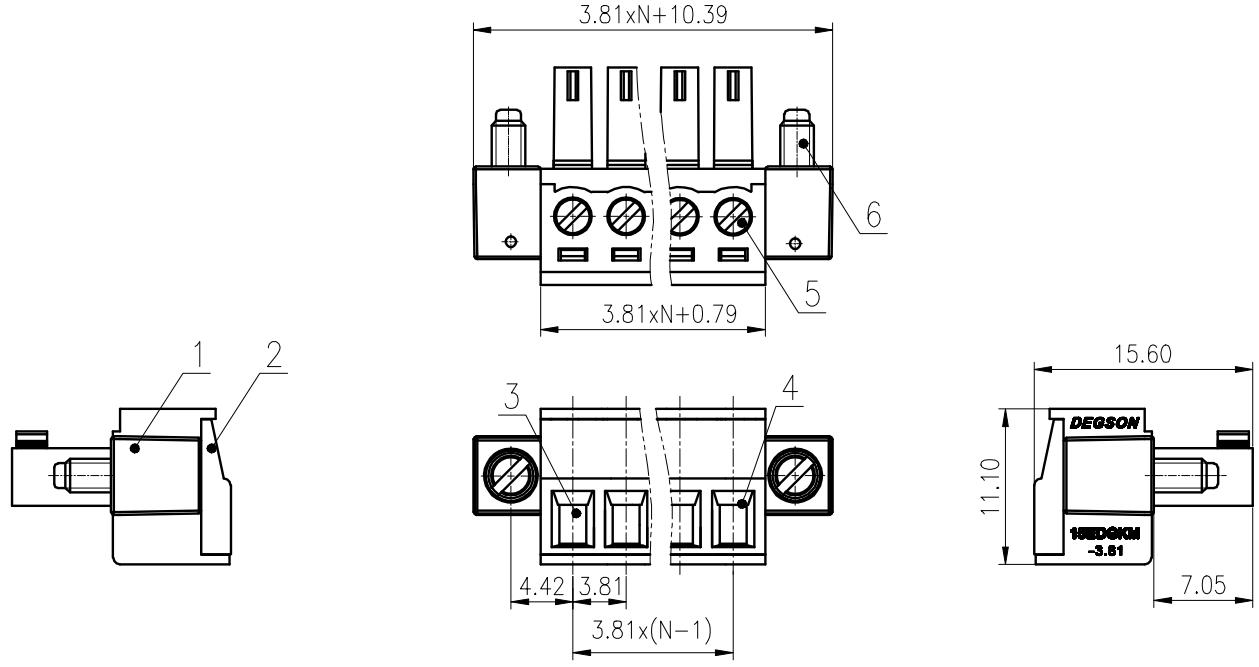

6	Screw 2	Steel	M2.5/Zn Plated
5	Screw 1	Steel	M2/Zn Plated
4	Cage	Copper Alloy	M2/Ni Plated
3	Clamp	Copper Alloy	Sn Plated
2	Cover	PA66	UL94V-0
1	Housing	PA66	UL94V-0

ITEM	NAME OF PART	MATERIAL	NOTES
UL 标准/UL Standard:		B	C
额定电压/电流/Rated Voltage(V)/Current(A)		300/8	300/8
IEC 标准/IEC Standard:			
过压类别/Overvoltage Category/污染等级/Pollution Degree		II/2	
额定电压/电流/Rated Voltage(V)/Current(A)		250/7	
额定脉冲电压(kV)/Rate Impulse Voltage(kV)		2.5	
螺丝扭矩/Torque Tightening(N·m/Lb.in)		M2, 0.2/1.77	
线径范围(硬线和软线)/Wire Range(rigid and flexible)(mm <sup>2</sup> /AWG)		0.5~1.5/28~16	
间距/Pitch(mm)/线数范围/Poles		3.81/N=02~24P	
剥线长度/Stripping length(mm)		6~7	
使用温度范围/Operating temperature(°C)		-40~+105	
符合RoHS环保要求/Conform to RoHS		Yes	

MATERIAL: /	SURFACE: /		
MAT NO.: /	<b>宁波高松电子有限公司</b> <b>NINGBO DEGSON ELECTRICAL CO., LTD</b>		
STATUS: /			
APPD: LanCH 2020.05.27	NAME: 15EDGKM-3.81-XXP-1Y-00A(H)		
CHKD: YuJZ 2020.05.27	DRAWING NO.: 15EDGKM-3.81-C01		
DRFT: FRZ 2016.01.26	REV	T1	
④	SIZE: A4	TYPE: CUSTOMER DRAWING	SCALE: 2:1 SHEET 1/1

REV	ECN	DESCRIPTION	DRFT	DATE