



SIM7020G

Hardware Design

LPWA Module

SIMCom Wireless Solutions Limited

Building B, SIM Technology Building, No.633, Jinzhong Road

Changning District, Shanghai P.R.China

Tel: 86-21-31575100

support@simcom.com

www.simcom.com

Document Title:	SIM7020G Hardware Design
Version:	1.01
Date:	2020-06-02
Status:	Released

GENERAL NOTES

SIMCOM OFFERS THIS INFORMATION AS A SERVICE TO ITS CUSTOMERS TO SUPPORT THE APPLICATION AND ENGINEERING EFFORTS THAT USE THE PRODUCTS DESIGNED BY SIMCOM. THE INFORMATION PROVIDED IS BASED ON THE REQUIREMENTS SPECIFICALLY FROM THE CUSTOMERS. SIMCOM HAS NOT UNDERTAKEN ANY INDEPENDENT SEARCH FOR ADDITIONAL RELEVANT INFORMATION, INCLUDING ANY INFORMATION THAT MAY BE IN THE CUSTOMER'S POSSESSION. FURTHERMORE, THE SYSTEM VALIDATION OF THE PRODUCT DESIGNED BY SIMCOM WITHIN A LARGER ELECTRONIC SYSTEM REMAINS THE RESPONSIBILITY OF THE CUSTOMER OR THE CUSTOMER'S SYSTEM INTEGRATOR. ALL SPECIFICATIONS SUPPLIED HEREIN ARE SUBJECT TO CHANGE WITHOUT NOTICE.

COPYRIGHT

THIS DOCUMENT CONTAINS THE PROPRIETARY TECHNICAL INFORMATION WHICH IS THE PROPERTY OF SIMCOM LIMITED, COPYING OF THIS DOCUMENT, GIVING IT TO OTHERS, THE USING OR COMMUNICATION OF THE CONTENTS THEREOF ARE FORBIDDEN WITHOUT THE OFFICIAL AUTHORITY BY SIMCOM. OFFENDERS ARE LIABLE TO THE PAYMENT OF THE DAMAGES. ALL RIGHTS ARE RESERVED IN THE EVENT OF GRANT OF A PATENT OR THE REGISTRATION OF A UTILITY MODEL OR DESIGN. ALL SPECIFICATIONS SUPPLIED HEREIN ARE SUBJECT TO CHANGE WITHOUT NOTICE.

SIMCom Wireless Solutions Limited

Building B, SIM Technology Building, No.633 Jinzhong Road, Changning District, Shanghai P.R.China
Tel: +86 21 31575100
Email: simcom@simcom.com

For more information, please visit:

<https://www.simcom.com/download/list-863-en.html>

For technical support, or to report documentation errors, please visit:

<https://www.simcom.com/ask/> Or email to: support@simcom.com

Copyright © Shanghai SIMCom Wireless Solutions Ltd. 2020

Version History

Date	Version	Description of change	Author
2019-01-15	1.00	Original	Olivier.Wu Lijuan.yin
2020-05-11	1.01	Update	OLIVIER.WU

SIMCom
Confidential

Contents

Version History	3
Contents	4
Table Index	6
Figure Index	8
1 . Introduction	9
1.1 Product Outline.....	9
1.2 Hardware Interface Overview.....	10
1.3 Hardware Block Diagram.....	10
1.4 Functional Overview.....	11
2 . Package Information	12
2.1 Pin Assignment Overview.....	12
2.2 Pin Description.....	14
2.3 Mechanical Information.....	17
2.4 Footprint Recommendation.....	18
2.5 Paste mask Recommendation.....	19
3 . Interface Application	20
3.1 Power Supply.....	20
3.2 Power Supply Design Guide.....	20
3.3 Voltage Monitor.....	24
3.4 Power on/Power off/Reset Function.....	24
3.4.1 Power on.....	24
3.4.2 Power off.....	26
3.4.3 Reset Function.....	28
3.5 UART Interface.....	29
3.5.1 UART Design Guide.....	29
3.5.2 RI and DTR Behavior.....	31
3.6 USB Interface.....	32
3.7 SIM Interface.....	33
3.7.1 SIM Application Guide.....	34
3.7.2 Recommended SIM CardHolder.....	35
3.8 Network status.....	36
3.9 ADC.....	37
3.10 Power Supply Output.....	37
3.11 I2C Interface.....	38
3.12 SPI Interface.....	39
4 . RF Specifications	41

4.1	LTE RF Specifications	41
4.2	LTE Antenna Design Guide	43
4.3	RF traces note	44
4.3.1	RF traces layout	44
4.3.2	LTE ANT and other system ANT decoupling	45
5	. Electrical Specifications	46
5.1	Absolute maximum ratings	46
5.2	Operating conditions	46
5.3	Operating Mode	48
5.3.1	Operating Mode Definition	48
5.3.2	Sleep mode	49
5.3.3	Minimum functionality mode and Flight mode	49
5.3.4	Power Saving Mode (PSM)	49
5.3.5	Extended Mode DRX (e-DRX)	51
5.4	Current Consumption	51
5.5	ESD Notes	53
6	.SMT Production Guide	54
6.1	Top and Bottom View of SIM7020G	54
6.2	Typical SMT Reflow Profile	54
6.3	Moisture Sensitivity Level (MSL)	55
6.4	Baking Requirements	55
7	. Packaging	57
8	. Appendix	60
8.1	Related Documents	60
8.2	Terms and Abbreviations	62
8.3	Safety Caution	64

Table Index

Table 1: SIM7020G frequency bands and air interface.....	9
Table 2: General features	11
Table 3: Pin definition	13
Table 4: IO parameters definition	14
Table 5: Pin description.....	14
Table 6: VBAT pins electronic characteristic.....	20
Table 7: The path of the power supply	21
Table 8: VDET+PMOS&LDO & diode:	22
Table 9: Recommended TVS diode list	23
Table 10: Power on timing and electronic characteristic.....	25
Table 11: Power off timing and electronic characteristic.....	27
Table 12: RESET pin electronic characteristic	28
Table 13: Recommended TVS list.....	32
Table 14: SIM electronic characteristic in 1.8V mode (SIM_VDD=1.8V)	33
Table 15: SIM electronic characteristic 3.0V mode (SIM_VDD=3V).....	33
Table 16: Molex SIM socket pin description	35
Table 17: NETLIGHT pin status.....	36
Table 18: ADC electronic characteristics.....	37
Table 19: Electronic characteristic.....	38
Table 20: Pin definition of the I2C	38
Table 21: I2C multiplexing function	39
Table 22: Pin definition of the SPI	39
Table 23: Conducted transmission power	41
Table 24: Maximum Power Reduction (MPR) for UE category NB2 Power Class 3.....	42
Table 25: E-UTRA operating bands	42
Table 26: CAT-NB2 Reference sensitivity (QPSK)	42
Table 27: Trace loss	43
Table 28: Recommended TVS.....	43
Table 29: Absolute maximum ratings.....	46
Table 30: Recommended operating ratings.....	46
Table 31: 1.8V Digital I/O characteristics*	46
Table 32: Operating temperature.....	47
Table 33: Operating mode Definition	48
Table 34: RTC_GPIO0/RTC_EINT characteristics	50
Table 35: Current consumption on VBAT Pins (VBAT=3.3V).....	51
Table 36: The ESD performance measurement table.....	53
Table 37: Moisture Sensitivity Level and Floor Life	55
Table 38: Baking requirements	56
Table 39: Tray size.....	58
Table 40: Small Carton size	58

Table 41: Big Carton size.....	59
Table 42: Related Documents.....	60
Table 43: Terms and Abbreviations.....	62
Table 44: Safety Caution	64

SIMCom
Confidential

Figure Index

Figure 1: SIM7020G block diagram	10
Figure 2: Pin assignment overview	12
Figure 3: Dimensions (Unit: mm).....	17
Figure 4: Footprint recommendation (Unit: mm).....	18
Figure 5: Paste mask SMT stencil footprint outline (Unit: mm)	19
Figure 6: Recommended power supply reference design circuit	21
Figure 7: Power supply application circuit	23
Figure 8: Reference power on/off circuit	24
Figure 9: Power on timing sequence	25
Figure 10: Power off timing sequence	26
Figure 11: Reference reset circuit	28
Figure 12: UART full modem.....	29
Figure 13: UART null modem	29
Figure 14: Reference circuit of level shift.....	30
Figure 15: TX level matching circuit.....	30
Figure 16: RX level matching circuit	31
Figure 17: RI behaviour (SMS and URC report)	31
Figure 18: USB reference circuit	32
Figure 19: SIM interface reference circuit.....	34
Figure 20: Molex SIM card socket.....	35
Figure 21: NETLIGHT reference circuit.....	36
Figure 22: Power on sequence of the VDD_EXT	37
Figure 23: Power on sequence of the VDD_3V3	38
Figure 24: SPI interface level conversion reference circuit.....	40
Figure 25: Antenna matching circuit (MAIN_ANT).....	43
Figure 26: RF trace should be far away from other high speed signal lines	44
Figure 27: The distance between GND to the inner conductor of SMA	45
Figure 28: PWRKEY or RTC_EINTwake up PSM sequence	50
Figure 29: Top and bottom view of SIM7020G	54
Figure 30: The ramp-soak-spike reflow profile of SIM7020G	54
Figure 31: packaging diagram	57
Figure 32: Tray drawing	57
Figure 33: Small carton drawing.....	58
Figure 34: Big carton drawing.....	58

1. Introduction

This document describes SIM7020G hardware interface in great detail. The document can help customer to quickly understand SIM7020G interface specifications, electrical and mechanical details. With the help of this document and other SIM7020G application notes, customer guide, customers can use SIM7020G to design various applications quickly.

1.1 Product Outline

The SIM7020G module support LTE CAT-NB1 and LTE CAT-NB2. With a tiny configuration of 17.6*15.7*2.3mm, SIM7020G can meet almost all the space requirements in customers' applications, such as water meter instruments, tracking devices, home security locks and other aspects. And the physical dimension is compatible with the packaging of SIM868.

Table 1: SIM7020G frequency bands and air interface

Standard	Frequency	Variants SIM7020G
LTE-FDD	B1	✓
	B2	✓
	B3	✓
	B4	✓
	B5	✓
	B8	✓
	B12	✓
	B13	✓
	B17	✓
	B18	✓
	B19	✓
	B20	✓
	B25	✓
	B26	✓
	B28	✓
	B66	✓
	B70	✓
B71	✓	
B85	✓	

1.2 Hardware Interface Overview

The interfaces are described in detail in the next chapters include:

- Power Supply
- USB Interface
- UART Interface
- SPI Interface
- I2C Interface
- SIM Interface
- ADCs
- Power Output
- GPIOs
- Antenna Interface

1.3 Hardware Block Diagram

The block diagram of the SIM7020G module is shown in the figure below.

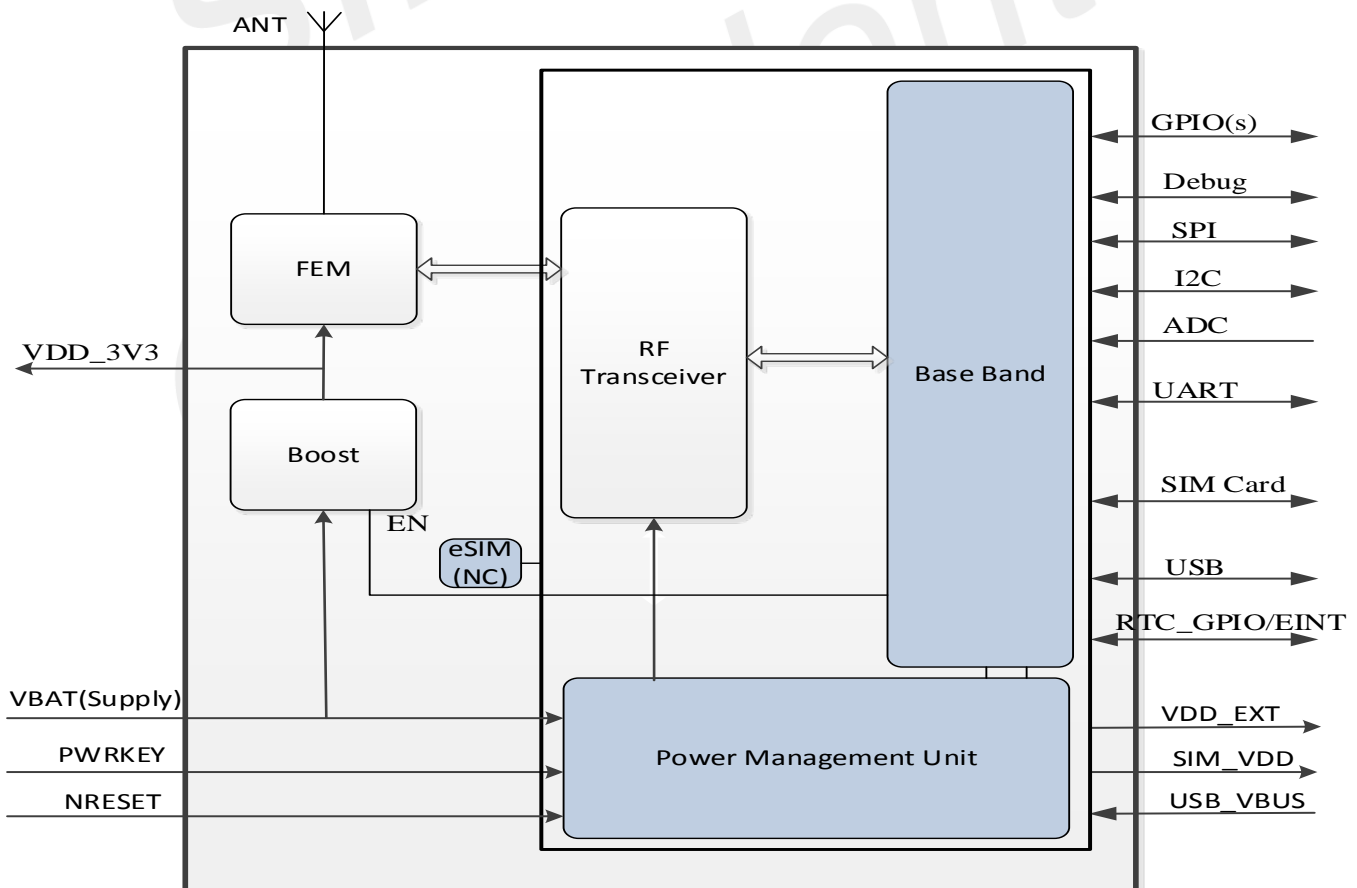

Figure 1: SIM7020G block diagram

1.4 Functional Overview

Table 2: General features

Feature	Implementation
Power supply	Power supply voltage 2.1~3.6V, Typ=3.3V
Power saving	Current in sleep mode: 236uA (at+cfun=0) Current in PSM mode: 3.4uA
Radio frequency bands	Please refer to the table 1
Transmitting power	LTE23dBm
Data Transmission Throughput	LTE CAT NB2: 126Kbps (DL) LTE CAT NB2: 150Kbps (UL)
Antenna	LTE antenna.
SMS	MT, MO, Text and PDU mode
SIM interface	Support identity card: 1.8V/ 3V
UART1 interface	A full modem serial port by default Baud rate: default: auto baud rate Can be used as the AT commands or data stream channel Support RTS/CTS hardware handshake
UART2 interface	Baud rate: It can be 921600bps when used download mode. Can be used for debugging and upgrading firmware
USB	USB 1.1 interface for debugging (Log port can be selected by AT command.)
Firmware upgrade	Firmware upgrade over UART2 interface
Physical characteristics	Size: 17.6*15.7*2.3mm Weight: 1.3g±0.2g
Temperature range	Normal operation temperature: -30°C to + 80°C Extended operation temperature: -40°C to + 85°C* Storage temperature -45°C to + 90°C

NOTE

The performance will be reduced slightly from the 3GPP specifications if the temperature is outside the normal operating temperature range and still within the extreme operating temperature range.

2. Package Information

2.1 Pin Assignment Overview

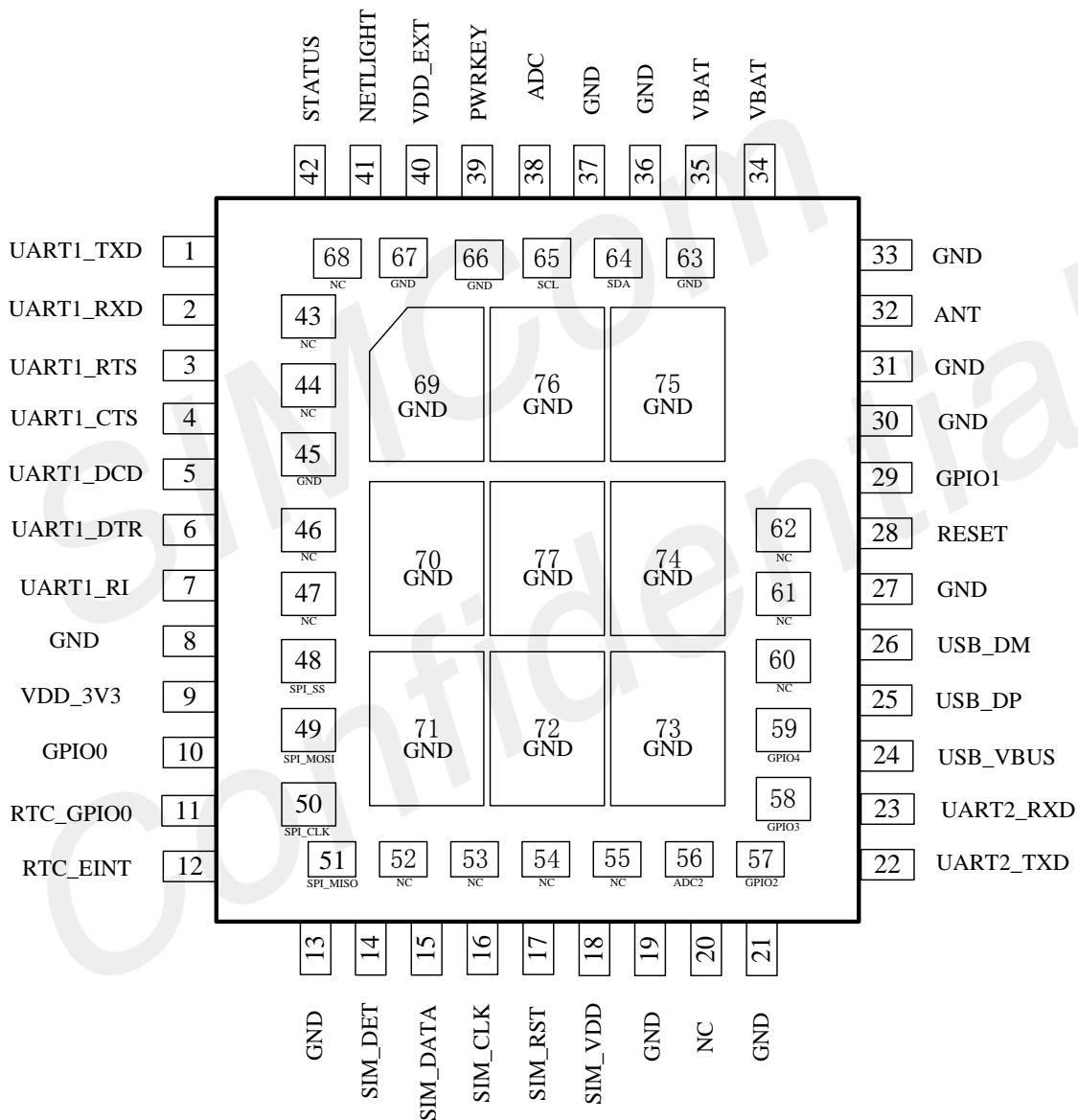

Figure 2: Pin assignment overview

NOTE

SIM7020G add PIN 43 - 73 in the inner ring, PIN in the outer ring is completely consistent with that in SIM7020.

Table 3: Pin definition

Pin No.	Pin Name	Pin No.	Pin Name
1	UART1_TXD	38	ADC
2	UART1_RXD	39	PWRKEY
3	UART1_RTS	40	VDD_EXT
4	UART1_CTS	41	NETLIGHT
5	UART1_DCD	42	STATUS
6	UART1_DTR	43	NC
7	UART1_RI	44	NC
8	GND	45	GND
9	VDD_3V3	46	NC
10	GPIO0	47	NC
11	RTC_GPIO0	48	SPI_SS
12	RTC_EINT	49	SPI_MOSI
13	GND	50	SPI_CLK
14	SIM_DET	51	SPI_MISO
15	SIM_DATA	52	NC
16	SIM_CLK	53	NC
17	SIM_RST	54	NC
18	SIM_VDD	55	NC
19	GND	56	ADC2
20	NC	57	GPIO2
21	GND	58	GPIO3
22	UART2_TXD	59	GPIO4
23	UART2_RXD	60	NC
24	USB_VBUS	61	NC
25	USB_DP	62	NC
26	USB_DM	63	GND
27	GND	64	SDA
28	RESET	65	SCL
29	GPIO1	66	GND
30	GND	67	GND
31	GND	68	NC
32	ANT	69	GND
33	GND	70	GND
34	VBAT	71	GND
35	VBAT	72	GND
36	GND	73	GND
37	GND		

2.2 Pin Description

Table 4: IO parameters definition

Pin type	Description
PI	Power input
PO	Power output
AI	Analog input
AIO	Analog input/output
I/O	Bidirectional input /output
DI	Digital input
DO	Digital output
DOH	Digital output with high level
DOL	Digital output with low level
PU	Pull up
PD	Pull down

Table 5: Pin description

Pin name	Pin No.	Default status	Description	Comment
Power supply				
VBAT	34、35	PI	Power supply, voltage range: 2.1-3.6V.	
VDD_EXT	40	PO	Power output 1.8V for other external circuits with Max 50mA current output, such as level shift circuit. Not present in PSM mode.	If unused, keep it floating.
VDD_3V3	9	PO	Power output 3.3V for other external circuits with Max 50mA current output. Not present in PSM mode.	Voltage range 3.3V-3.5V(depend on VBAT). If unused, keep it floating.
GND	8、13、19、21、27、30、31、33、36、37、45、63、66、67、69-73		Ground	
System Control				
PWRKEY	39	DI, PU	System power on/off control input, active low. The efficient input level must be below 0.5V.	PWRKEY has been pulled up to VBAT via 40Kohm resistor internally.
RESET	28	DI, PU	System reset control input, active low.	RESET has been pulled up to VBAT via 40Kohm

				resistor internally.
SIM interface				
SIM_DATA	15	I/O, PU	SIM Card data I/O	All lines of SIM interface should be protected against ESD.
SIM_RST	17	DO	SIM Reset	
SIM_CLK	16	DO	SIM clock	
SIM_VDD	18	PO	Power output for SIM card, its output Voltage depends on SIM card type automatically.	
SIM_DET	14	DI	SIM card detecting input. (This function do not support yet in standard software.)	If used, keep a 100kΩ resistor pulling up to the VDD_EXT
USB				
USB_VBUS	24	DI,PD	Valid USB detection input with 2.5~5.25V detection voltage	USB interface for debugging
USB_DP	25	I/O	Positive line of the differential, bi-directional USB signal.	
USB_DM	26	I/O	Negative line of the differential, bi-directional USB signal.	
UART interface				
UART1_TXD	1	DOH	Transmit Data	If unused, keep them floating. Voltage Domain: 1.8V
UART1_RXD	2	DI, PU	Receive Data	
UART1_RTS	3	DI, PU	Request to send	
UART1_CTS	4	DOH	Clear to Send	
UART1_DCD	5	DOH	Data carrier detect	
UART1_DTR	6	DI, PU	Transmit Data	
UART1_RI	7	DOH	Ring Indicator	
UART2_TXD	22	DOH	Transmit Data	
UART2_RXD	23	DI, PU	Receive Data	
Indicate and Control in PSM Mode				
RTC_GPIO0	11	DO	In PSM mode, RTC_GPIO0 will change state from low to high when RTC_EINT receive an interrupt event to exit PSM. Enter PSM(RTC_GPIO0 is low) Exit PSM (RTC_GPIO0 is high)	Voltage Domain: VBAT
RTC_EINT	12	DI, PU	RTC_EINT can be used to wake up SIM7020G from PSM mode, which is pull up to VBAT, active is low.	
GPIO				
NETLIGHT	41	DO	LED control output as network status indication.	If unused, keep them floating. Voltage Domain: 1.8V
STATUS	42	DO	Operating status output. High level: Power on and firmware ready Low level: Power off	
GPIO0	10	IO	Do not pull down before power	

			on	
GPIO1	29	IO		
GPIO2	57	IO		
GPIO3	58	IO		
GPIO4	59	IO		
I2C interface				
SDA	64	I/O	Open drain output	If these pins are unused, keep floating.
SCL	65	I/O	Open drain output	
SPI interface				
SPI_MISO	51	DI	Host input and slave output signals	SPI MASTER If these pins are unused, keep floating. Voltage Domain: 1.8V
SPI_MOSI	49	DO	Host outputs slave input signals	
SPI_CLK	50	DO	Clock signal generated by the main device	
SPI_SS	48	DO	Slave enable signal controlled by master device	
RF interface				
ANT	32	AI	antenna	
Other interface				
ADC	38	AI	Analog-digital converter input. Voltage range: 0.1-1.4V.	If unused, keep them floating.
ADC2	56	AI		
NC	20		No connection.	Keep it floating

2.4 Footprint Recommendation

Recommended PCB
Footprint outline

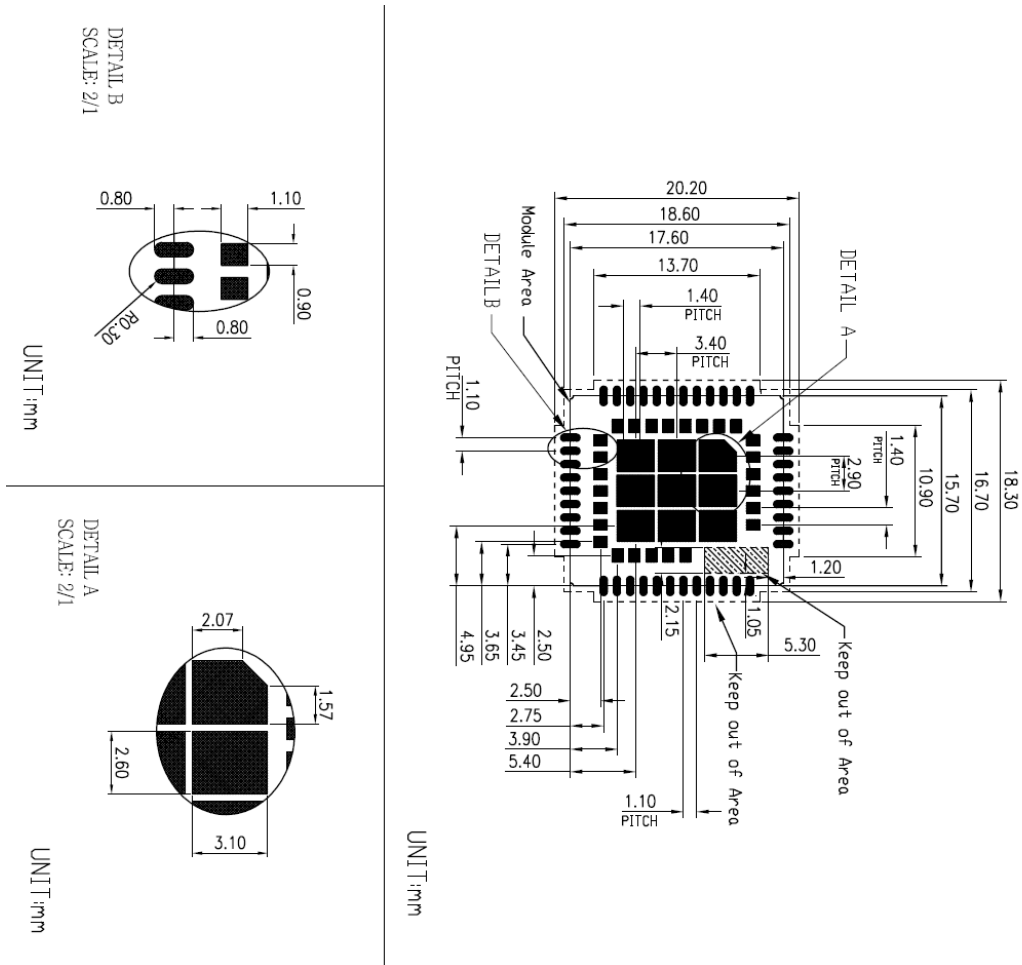
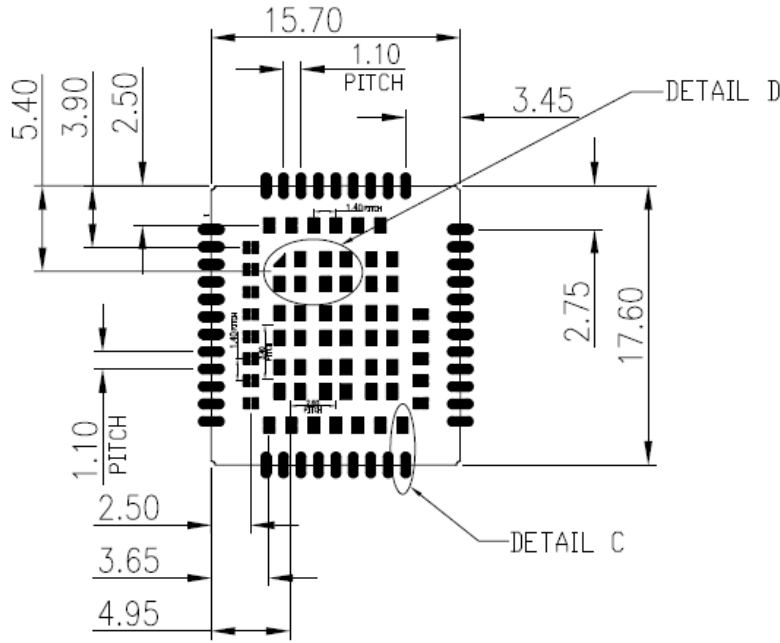

Figure 4: Footprint recommendation (Unit: mm)

2.5 Paste mask Recommendation

The recommended thickness of stencil foil is 0.15mm.

SMT stencil outline



UNIT:mm

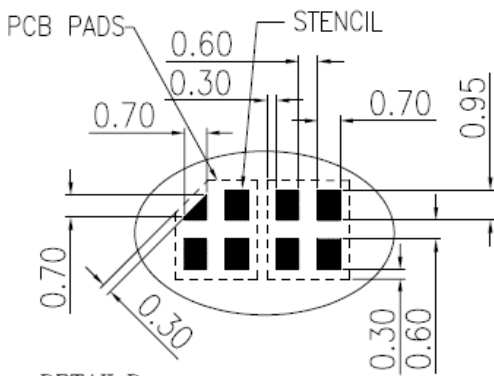

DETAIL D
SCALE: 2/1

UNIT:mm

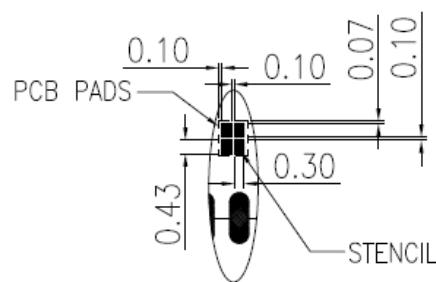

DETAIL C
SCALE: 2/1

UNIT:mm

Figure 5: Paste mask SMT stencil footprint outline (Unit: mm)

3. Interface Application

3.1 Power Supply

The power supply for SIM7020G must be able to provide sufficient instantaneous current up to more than 760mA@2.1V in order to satisfy the power supply current for maximum consumption.

Table 6: VBAT pins electronic characteristic

Symbol	Description	Min.	Typ.	Max.	Unit
VBAT	Module power voltage	2.1	3.3	3.6	V
I _{VBAT(peak)} @3.3V	Module power peak current in NB emission	500	-	-	mA
I _{VBAT(average)}	Module power average current in normal mode	Please refer to the table 32			
I _{VBAT(sleep)}	Power supply current in sleep mode				
I _{VBAT(PSM)}	Power supply current in PSM mode	-	3.4	-	uA
I _{VBAT(power-off)}	Module power current in power off mode.	-	-	12	uA

3.2 Power Supply Design Guide

In the design of the user, special attention must be paid to the design of the power supply to ensure the stable operation of the module. SIM7020G can support the use of Li-MnO₂ battery, DC (LDO/ DC-DC), Li-SOCI₂ battery and other external power supply, such as its reference design.

NOTE

If the power supply for VBAT pins can support up to 500mA@3.3V, using a total of more than 100uF capacitors is recommended, or else users must use a total of 300uF capacitors typically, in order to avoid the voltage drop. The module power peak current depends on the total capacitance. Using a total of 1000uF capacitors in the test that will reduce the peak current to 320mA.

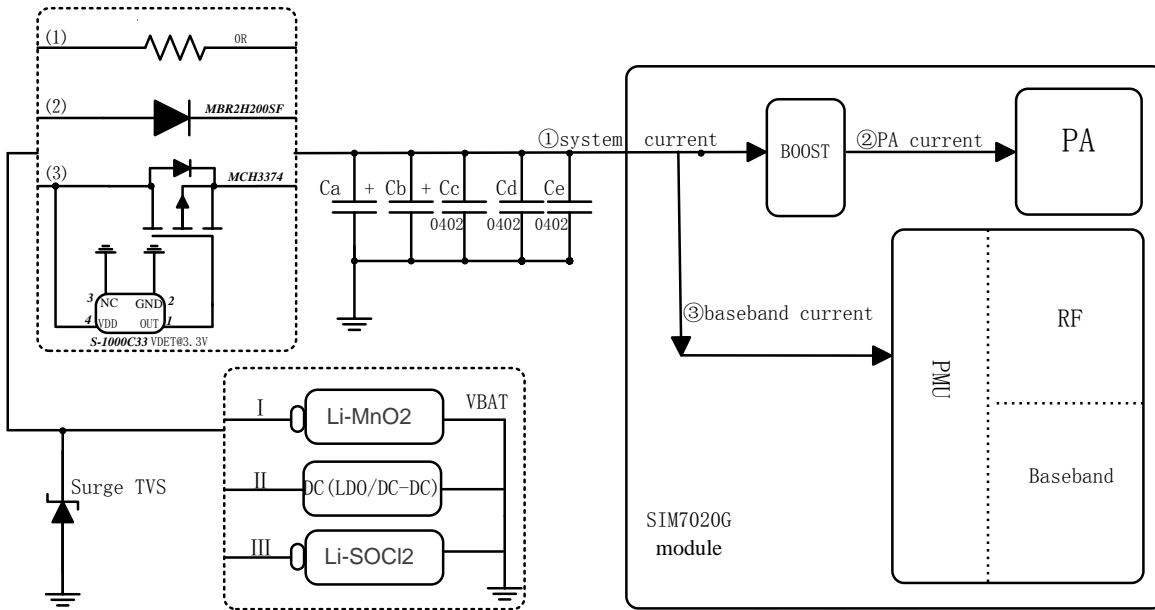

Figure 6: Recommended power supply reference design circuit

Table 7: The path of the power supply

NO.	VBAT power supply	The path of the power
1	I Li-MnO2	(1)
2	II DC (LDO/DC-DC)	(1)
3	III Li-SOCI2	(2)
4	III Li-SOCI2	(3)

NOTE

Using Li-SOCI2 battery, the open circuit voltage is about 3.8v, larger than the VBAT maximum 3.6v. It is necessary to add the schottky diode (column 3 of table 7) or voltage limiting circuit (column 4 of table 7) between the battery and the module, and lithium battery or DC can directly supply power (column 1/2 of table 7).

1、schottky diode: On-SEMI , MBR2H200SF;

2 、 voltage limiting circuit: VDET+PMOSFET : VDET IC Seiko S-1000C33-I4T1U , PMOSFET:On-SEMI ,MCH3374-TL-E (Pb-Free), MCH3374-TL-W (Pb-Free/Halogen Free);

3、 LDO DC: TI TPS7A92;

If the use of power adapter output 5V power supply or lithium ion battery: RT5707WSC

4、 VDET+PMOS&LDO & diode:

Table 8: VDET+PMOS&LDO & diode:

	VDET+PMOS	2A LDO DC TPS7A92	2A Diode MBR2H200SF
Cost	Mediate (Good)	high	less (BEST)
Solution Size	6.45mm ²	6.25mm ² (only TPS7A92)	4.455mm ²
VBAT operating range	Vmin: 2.1V Vmax: 3.8V (Good)	Vmin: 2.36V(=2.1V+Vdo) Vmax: 3.8V	Vmin: 3.0V(2.1V+0.9V@1A) Vmax: 3.8V (Bad)
Efficiency @Vin > 3.3V	$P_{loss} = 0.75V(V_f@1A) * 1A = 0.75W$	$P_{loss} = (3.8V-3.3V) * 1A = 0.5W$	$P_{loss} = 0.9V(V_f@1A) * 1A = 0.9W$
Efficiency @Vin < 3.3V	$P_{loss} = R_{on}(<0.125\Omega) * 1.652(A) < 0.34W(\text{Good})$	$P_{loss} = 0.26V * 1.65A = 0.429W$	$P_{loss} = 0.9V * 1.65A = 1.485W$
Current consumption impact	MAX < 0.9Ua (Good)	2.8mA=> 2.1mA(ground current)+0.7mA(VFB leakage) (Bad)	No extra current consumption (BEST)

NOTE

Comprehensive evaluation: VDET+PMOS is recommended.

LDO solution: LDO current capacity and low Iq are a compromise, and it is not competitive in performance and cost.

Schottky diode solution: price should be at an advantage but minimum input voltage should be at 3V at VBAT.

The power supply range of SIM7020G is from 2.1V to 3.6V. Recommended voltage is 3.3V. The transmitting burst will cause voltage drop and the power supply must be able to provide sufficient current up to 760mA@2.1V, Make sure that the voltage on the VBAT pins will never drop below 2.1V, or module will work abnormally.

NOTE

SYSTEM CURRENT EVALUAATE:

- ①system current=② PA current +③baseband current=760mA;
- ②Max.PA input current=400mA;
- ③Max.baseband current=20mA(Without other device on system);

If boost converter efficiency 85%;calculate boost input current=(400mA*3.3V)/0.85/2.1V=740mA;
*Boost output=3.3V/battery min.=2.1V.

Battery pulse current capability should be confirmed with battery vender. SELECT BATTERY CURRENT CAPABILITY >760mA

Based on the recommendations, the following combination is placed near the VBAT capacitance, near the module VBAT input, suggested to parallel a low ESR (ESR) = 0.7 Ω 100 uF Ca and Cb tantalum capacitor, and Cc 100 nF, Cd 100 pF(0402 size) and Ce22pF (0402 size) filtering capacitance, To improve RF performance and system stability .These capacitors should be put as close as possible to VBAT pads. Also, users should keep VBAT trace on circuit board wider than 1 mm to minimize PCB trace impedance.

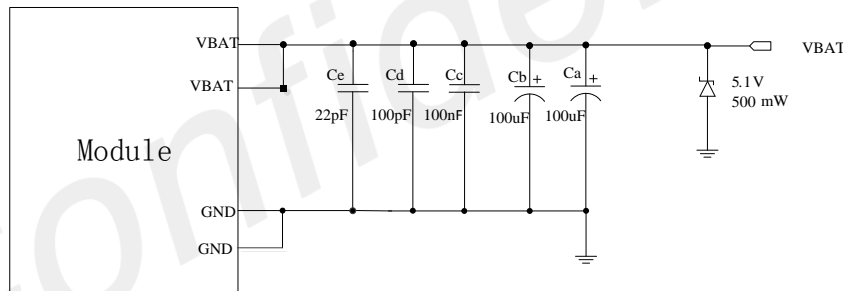

Figure 7: Power supply application circuit

In addition, for ESD protection, it is suggested to add a TVS diode near the VBAT PINs.

Table 9: Recommended TVS diode list

No.	Manufacturer	Part Number	Package
1	Prisemi	PESDHC2FD4V5B	DFN1006
2	Prisemi	PESDHC3D3V3U	SOD323
3	WILLsemi	ESD5651N-2/TR	DFN1006

3.3 Voltage Monitor

To monitor the VBAT voltage, the AT command “AT+CBC” can be used.

When the VBAT voltage is out of the range, the module will be power off when the overvoltage power-off function is enabled. The AT command “AT+CBATCHK=1” can be used to enable the overvoltage power-off function and the under-voltage power-off function.

NOTE

Under-voltage warning function and under-voltage power-off function are disabled by default. For more information about these AT commands, please refer to Document [1].

3.4 Power on/Power off/Reset Function

3.4.1 Power on

SIM7020G can be powered on by pulling the PWRKEY pin to ground. The PWRKEY pin has been pulled up with a resistance to VBAT internally, so it does not need to be pulled up externally. It is strongly recommended to put a 100nF capacitor and an ESD protection diode close to the PWRKEY pin, as it would strongly enhance the ESD performance of PWRKEY pin. Please refer to the following figure for the recommended reference circuit.

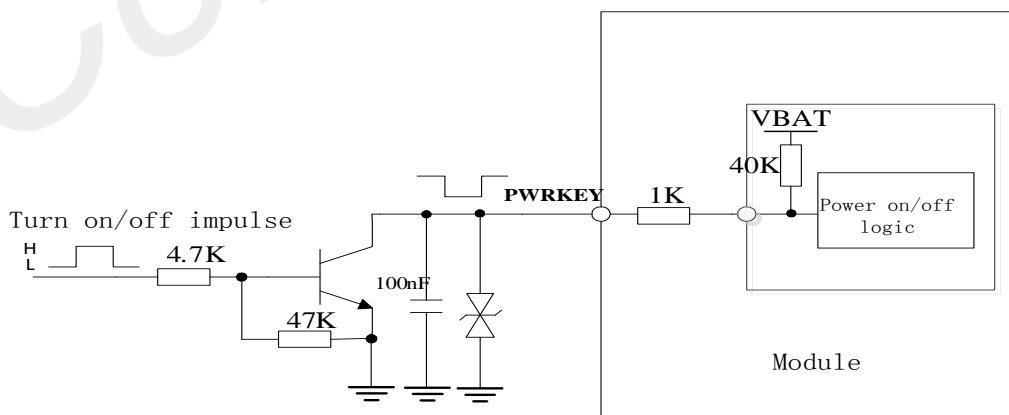

Figure 8: Reference power on/off circuit

NOTE

Do not directly ground the PWRKEY pin, and do not lower GPIO0 before starting the machine.

The power-on scenarios are illustrated in the following figure.

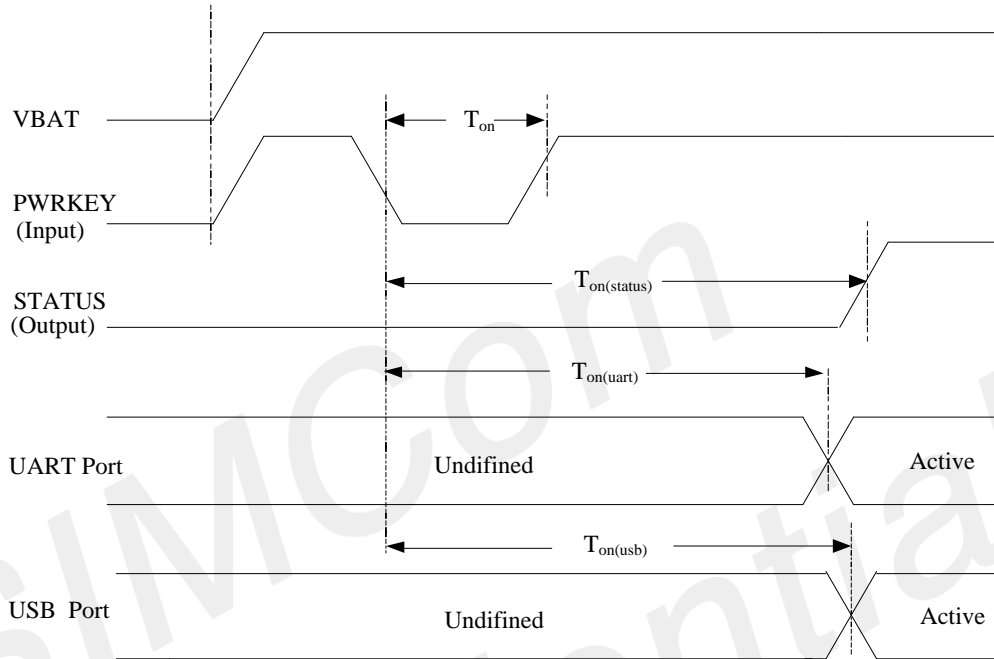

Figure 9: Power on timing sequence

Table 10: Power on timing and electronic characteristic

Symbol	Parameter	Min.	Typ.	Max.	Unit
T_{on}	The time of active low level impulse of PWRKEY pin to power on module	215	1000	-	ms
$T_{on(status)}$	The time from power-on issue to STATUS pin output high level(indicating power up ready)		440		ms
$T_{on(usb)}$	The time from power-on issue to UART port ready	2			s
$T_{on(usb)}$	The time from power-on issue to USB port ready		4		s
V_{IH}	Input high level voltage on PWRKEY pin	$0.7*VBAT$			V
V_{IL}	Input low level voltage on PWRKEY pin			$0.3*VBAT$	V

3.4.2 Power off

The following methods can be used to power off SIM7020G.

Method 1: Power off SIM7020G by pulling the PWRKEY pin to ground.

Method 2: Power off SIM7020G by AT command “AT+CPOWD=1”.

Method 3: over-voltage or under-voltage automatic power off. The function can be enabled by AT command “AT+CBATCHK=1”. Default is disabled.

NOTE

For details about “AT+CPOWD” and “AT+CBATCHK”, please refer to Document [1].

These procedures will make modules disconnect from the network and allow the software to enter a safe state, and save data before module be powered off completely.

The power off scenario by pulling down the PWRKEY pin is illustrated in the following figure.

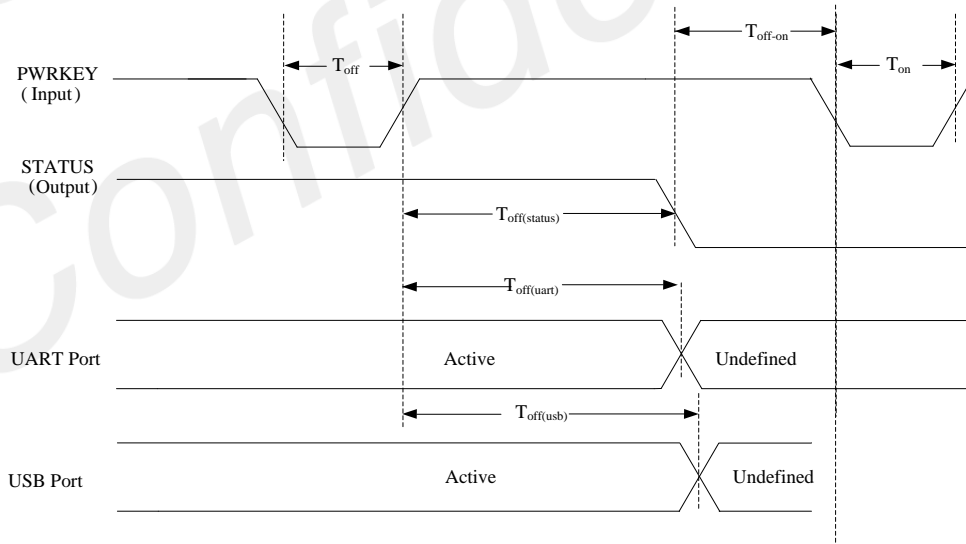

Figure 10: Power off timing sequence

Table 11: Power off timing and electronic characteristic

Symbol	Parameter	Time value			Unit
		Min.	Typ.	Max.	
T_{off}	The active low level time pulse on PWRKEY pin to power off module	1	1.5	-	s
$T_{off(status)}$	The time from power-off issue to STATUS pin output low level(indicating power off)*	-	-	1.1	s
$T_{off(uart)}$	The time from power-off issue to UART port off	-	-	1	s
$T_{off(usb)}$	The time from power-off issue to USB port off	-	-	1	s
T_{off-on}	The buffer time from power-off issue to power-on issue	5	-	-	s

NOTE

The STATUS pin can be used to detect whether module is powered on or not. When module has been powered on and firmware goes ready, STATUS will be high level, or else STATUS will still low level.

3.4.3 Reset Function

SIM7020G can be reset by pulling the RESET pin to ground.

NOTE

This function is only used as an emergency reset. The RESET pin will be ineffective in the power off mode.

The RESET pin has been pulled up to VBAT with a 40KΩ resistor internally. So it does not need to be pulled up externally. It is strongly recommended to put a 100nF capacitor and an ESD protection diode close to the RESET pin. Please refer to the following figure for the recommended reference circuit.

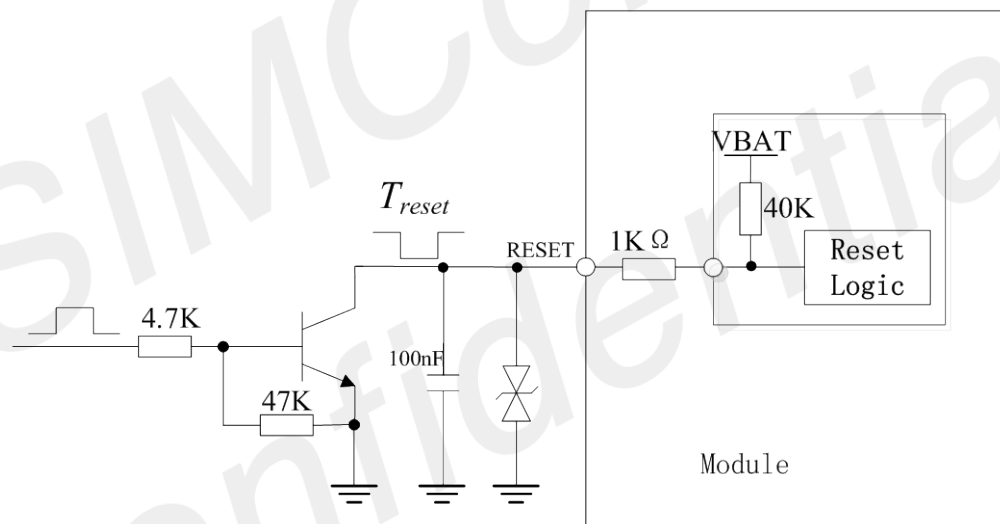

Figure 11: Reference reset circuit

Table 12: RESET pin electronic characteristic

Symbol	Description	Min.	Typ.	Max.	Unit
T_{reset}	The active low level time impulse on RESET pin to reset module	40	-	-	ms
V_{IH}	Input high level voltage	$0.7 \cdot V_{BAT}$			V
V_{IL}	Input low level voltage			$0.3 \cdot V_{BAT}$	V

3.5 UART Interface

SIM7020G provides a 7-wire UART1 (universal asynchronous serial transmission) interface as DCE (Data Communication Equipment). AT commands and data transmission can be performed through UART1 interface. UART2 can be used for debugging and download software.

3.5.1 UART Design Guide

The following figures show the reference design.

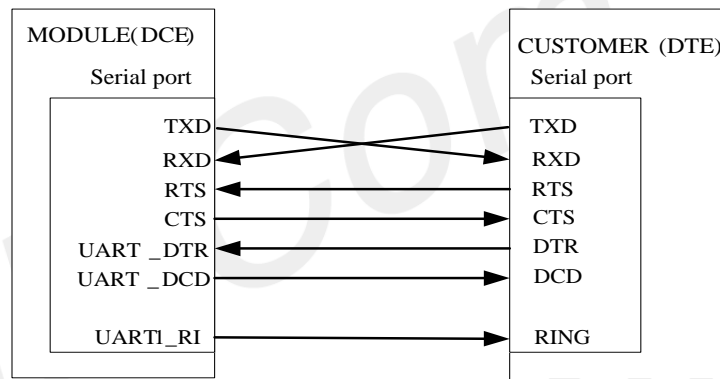

Figure 12: UART full modem

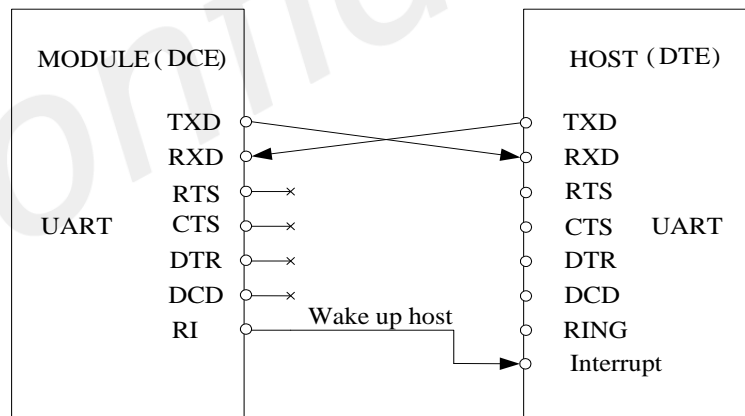

Figure 13: UART null modem

The SIM7020G UART is 1.8V voltage interface. If user's UART application circuit is 3.3V voltage interface, the level shifter circuits should be used for voltage matching. The TXB0108RGYR provided by Texas Instruments is recommended. The following figure shows the voltage matching reference design.

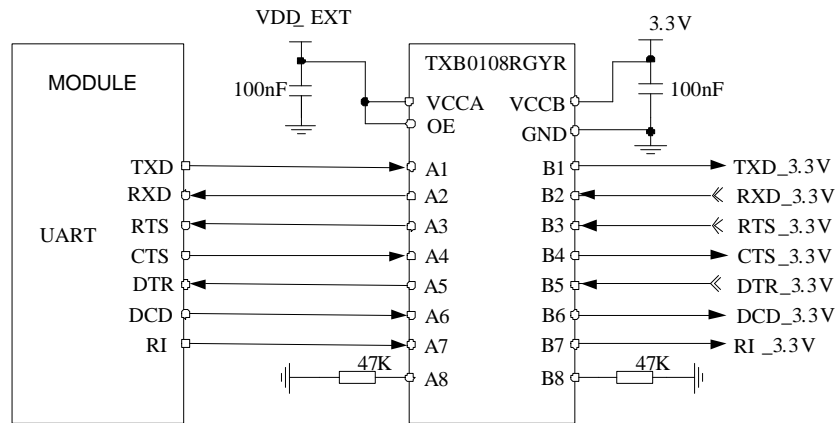

Figure 14: Reference circuit of level shift

NOTE

- 1、 When it uses the level shifter IC, the pullupresistance on TXD_3.3V, RTS_3.3V, DCD_3.3V should not be less than 47KΩ;
- 2、 Special note: the module is DCE, RTS is defined as the INPUT signal, DTE should be connected to the OUTPUT signal, CTS is defined as the OUTPUT signal, DTE should be connected to the INPUT signal.

Also the following reference circuit is recommended:

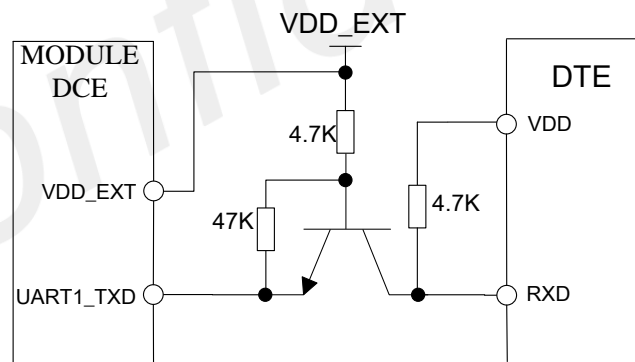

Figure 15: TX level matching circuit

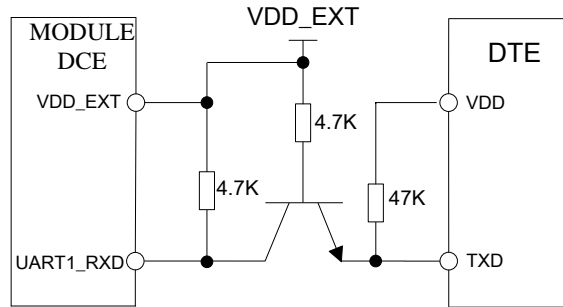

Figure 16: RX level matching circuit

NOTE

The default baud rate is 0bps (auto baud rate). The triode conversion circuit is not suitable for high baud rate more than 460800. When using UART2 for downloading software, the baud rate is 921600bps, please pay attention to the device's speed support.

3.5.2 RI and DTR Behavior

The RI pin description:

The RI pin can be used to interrupt output signal to inform the host controller such as application CPU. Before that, users must use AT command "AT+CFGRI=1" to enable this function. Normally RI will keep high level until certain conditions such as receiving SMS, or a URC report coming, then it will output a low level pulse 120ms, in the end, it will become high level.

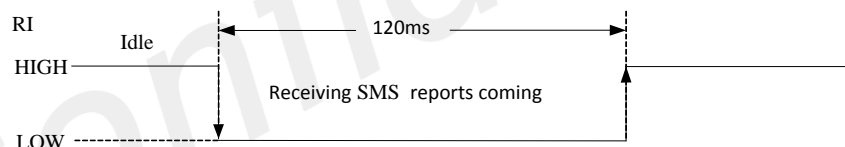

Figure 17: RI behaviour (SMS and URC report)

NOTE

For more details of AT commands about UART, please refer to document [1].

The DTR pin description:

After setting the AT command "AT+CSCLK=1", SIM7020G will enter sleep mode by pulling up the DTR pin when module is in idle mode. In sleep mode, the UART is unavailable. When SIM7020G enters sleep mode, pulling down DTR can wake up module.

After setting the AT command "AT+CSCLK=0", SIM7020G will do nothing when the DTR pin is pulling up.

3.6 USB Interface

The SIM7020G contains a USB interface compliant with the USB1.1 specification as a peripheral, but the USB charging function is not supported.

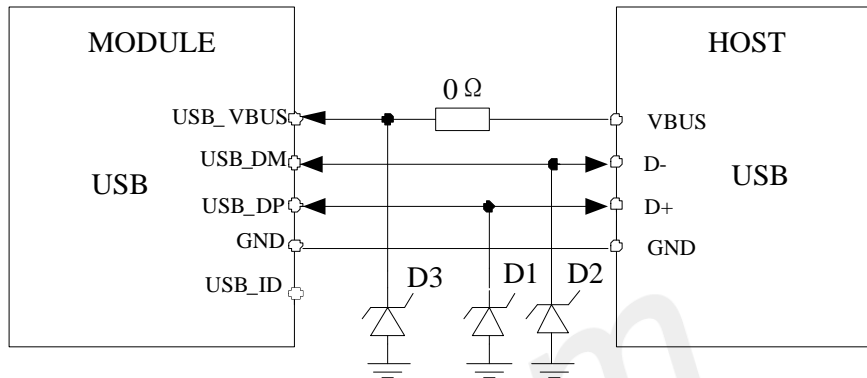

Figure 18: USB reference circuit

Because of the high speed on USB bus, more attention should be paid to the influence of the junction capacitance of the ESD component on USB data lines.

Table 13: Recommended TVS list

No.	Manufacturer	Part Number	Description	Package
1	ON Semi	ESD9L5.0ST5G	TVS 5V 0.5PF 150mW RO	SOD-923
2	TOSHIBA	DF2S6.8UFS	TVS 5V 2PF 150mW RO	SOD-923
3	ON Semi	ESD9L5.0ST5G	TVS 5V 0.5PF 150mW RO	SOD-923
4	TOSHIBA	DF2S6.8UFS	TVS 5V 2PF 150mW RO	SOD-923

3.7 SIM Interface

SIM7020G supports both 1.8V and 3.0V SIM Cards.

Table 14: SIM electronic characteristic in 1.8V mode (SIM_VDD=1.8V)

Symbol	Parameter	Min.	Typ.	Max.	Unit
SIM_VDD	LDO power output voltage	1.75	1.8	1.95	V
V_{IH}	High-level input voltage	0.65*SIM_VDD	-	SIM_VDD +0.3	V
V_{IL}	Low-level input voltage	-0.3	0	0.25*SIM_VDD	V
V_{OH}	High-level output voltage	SIM_VDD -0.45	-	SIM_VDD	V
V_{OL}	Low-level output voltage	0	0	0.45	V

Table 15: SIM electronic characteristic 3.0V mode (SIM_VDD=3V)

Symbol	Parameter	Min.	Typ.	Max.	Unit
SIM_VDD	LDO power output voltage	2.75	3	3.05	V
V_{IH}	High-level input voltage	0.65*SIM_VDD	-	SIM_VDD +0.3	V
V_{IL}	Low-level input voltage	-0.3	0	0.25*SIM_VDD	V
V_{OH}	High-level output voltage	SIM_VDD -0.45	-	SIM_VDD	V
V_{OL}	Low-level output voltage	0	0	0.45	V

3.7.1 SIM Application Guide

It is recommended to use an ESD protection component such as ESDA6V1W5 produced by ST (www.st.com) or SMF15C produced by ON SEMI (www.onsemi.com). Note that the SIM peripheral circuit should be close to the SIM card socket. The following figure shows the 6-pin SIM card holder reference circuit.

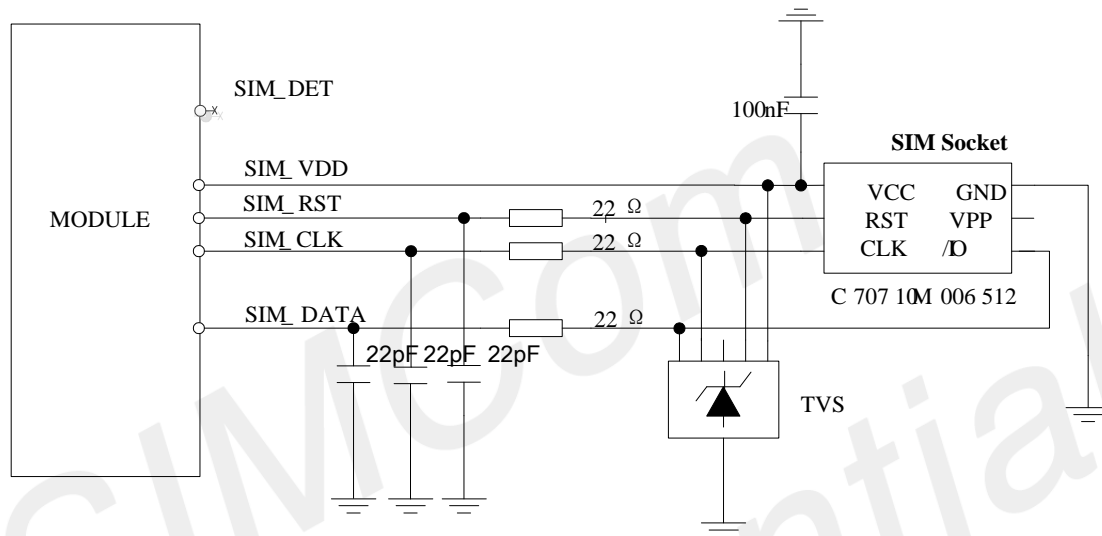

Figure 19: SIM interface reference circuit

NOTE

A 100nF capacitor on SIM_VDD is used to reduce interference. For more details of AT commands about SIM, please refer to document [1]. SIM_CLK is very important signal, the rise time and fall time of SIM_CLK should be less than 40ns, otherwise the SIM card might not be initialized correctly. If SIM_DET is used, a 10KΩ resistor is necessary to pulling up to the power VDD_EXT.

3.7.2 Recommended SIM CardHolder

It is recommended to use the 6-pin SIM socket such as [503960-0696](https://www.molex.com/molex/products/part-detail/memory_card_socket/5039600696) produced by Molex. User can visit https://www.molex.com/molex/products/part-detail/memory_card_socket/5039600696 for more information about the holder.

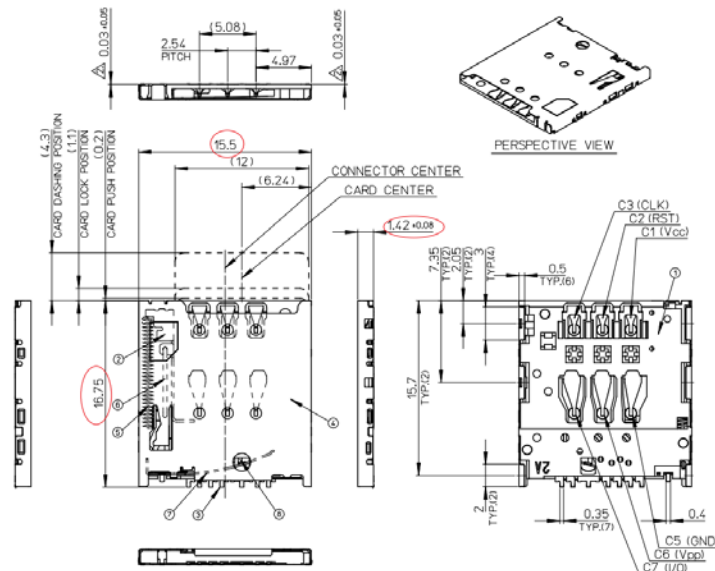

Figure 20: Molex SIM card socket

Table 16: Molex SIM socket pin description

Pin	Signal	Description
C1	SIM_VDD	SIM Card Power supply.
C2	SIM_RST	SIM Card Reset.
C3	SIM_CLK	SIM Card Clock.
C5	GND	Connect to GND.
C6	VPP	
C7	SIM_DATA	SIM Card data I/O.

SIM card circuit is susceptible to interference, causing the SIM card failures or some other situations, it is strongly recommended to follow these guidelines while designing:

- Make sure that SIM card holder should far away from NB_IOT antenna while in PCB layout.
- SIM traces should keep away from RF lines, VBAT and high-speed signal lines.
- The traces should be as short as possible.
- Keep SIM holder's GND connect to main ground directly.
- Shielding the SIM card signal by ground well.
- Recommended to place a 100nF capacitor on SIM_VDD line and keep close to the holder.
- Add some TVS and the parasitic capacitance should not exceed 50pF, and 22Ω resistor in serials the SIM signal could enhance ESD protection.

3.8 Network status

The NETLIGHT pin is used to control Network Status LED, its reference circuit is shown in the following figure.

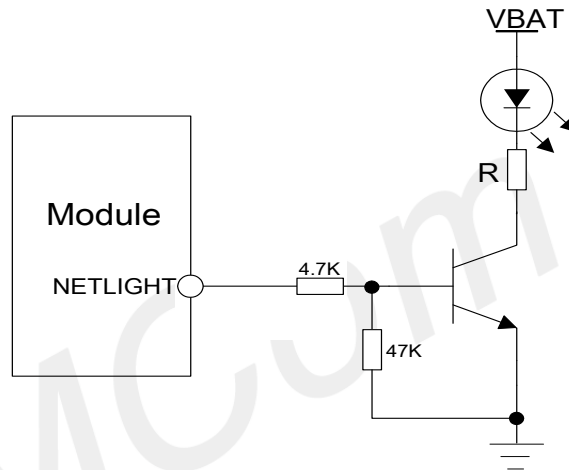

Figure 21: NETLIGHT reference circuit

NOTE

The value of the resistor named "R" depends on the LED characteristic.

Table 17: NETLIGHT pin status

NETLIGHT pin status	Module status
64ms ON, 800ms OFF	No registered network
64ms ON, 3000ms OFF	Registered network
64ms ON, 300ms OFF	Data transmit
OFF	Power off or PSM mode

NOTE

NETLIGHT output low level as "OFF", and high level as "ON".

3.9 ADC

SIM7020G has a dedicated ADC pin. It is available for digitizing analog signals such as battery voltage and so on. The electronic specifications are shown in the following table.

Table 18: ADC electronic characteristics

Characteristics	Min.	Typ.	Max.	Unit
Resolution	–	10	–	Bits
Input Range	0.1	–	1.4	V

NOTE

“AT+CADC” can be used to read the voltage of the ADC pin, for more details, please refer to document [1].

3.10 Power Supply Output

SIM7020G has a LDO power output named VDD_EXT. The output voltage is 1.8V. Meanwhile it has a DCDC power output named VDD_3V3, which voltage range is 3.3V-3.5V (depend on VBAT). Both of them are not present in PSM mode.

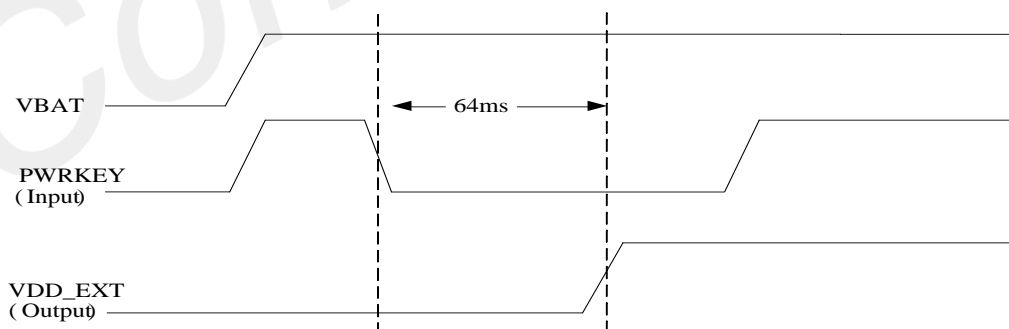

Figure 22: Power on sequence of the VDD_EXT

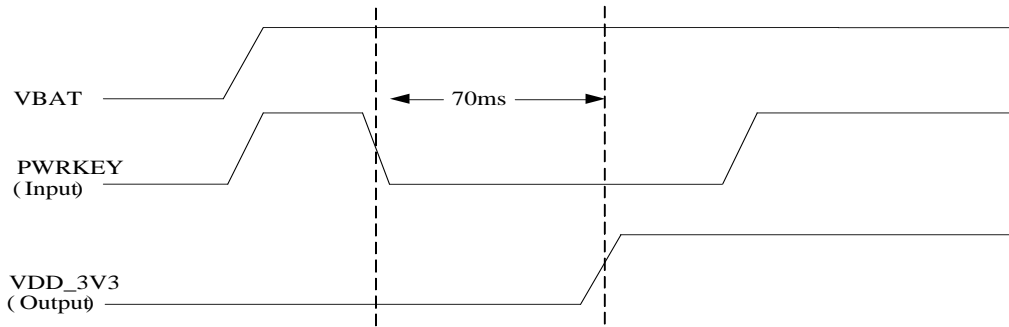

Figure 23: Power on sequence of the VDD_3V3

Table 19: Electronic characteristic

Pin name	Description	Min.	Typ.	Max.	Unit
VDD_EXT					
V _{VDD_EXT}	Output voltage	1.7	1.8	1.9	V
I _o	Output current	-	-	50	mA
VDD_3V3					
V _{VDD_3V3}	Output voltage	3.2	3.3	VBAT-0.1	V
I _o	Output current	-	-	50	mA

3.11 I2C Interface

The SIM7020G provides an I2C interface which is only used in the embedded AT application.

Table 20: Pin definition of the I2C

Pin name	Pin number	Description	Comment
SCL	65	I2C serial bus clock	Voltage Domain: 1.8V
SDA	64	I2C serial bus data	

NOTE

1. This function is not supported in the standard firmware. If customer wants this function, the firmware must be customized. Please contact SIMCom for more details.
2. If customer design I2C please pull up to VDD_EXT.
3. I2C is master mode 400kbps, up to 3.4Mbps, supporting 7-bit/10-bit addressing.

Table 21: I2Cmultiplexing function

Pin name	Pin number	Mode 0(default)	Mode 1
SCL	74	SCL	GPIO6
SDA	75	SDA	GPIO7

NOTE

Multiplexing function need different software supply.

3.12 SPI Interface

The SIM7020G provides an SPI interface(master mode), It could be used as SPI interface in the embedded AT application..

Table 22: Pin definition of the SPI

Pin name	Pin number	Description	Comment
SPI_MISO	51	Host input and slave output signals	
SPI_MOSI	49	Host outputs slave input signals	SPI MASTER
SPI_CLK	50	Clock signal generated by the main device	Voltage Domain: 1.8V
SPI_SS	48	Slave enable signal controlled by master device	

SPI interface voltage domain is 1.8v.If the voltage domain of the slave device system is 3.3v, a level switch shall be added between the module and the slave device Converter; It is recommended to use a level converter that supports SPI data rate. The reference circuit is shown below:

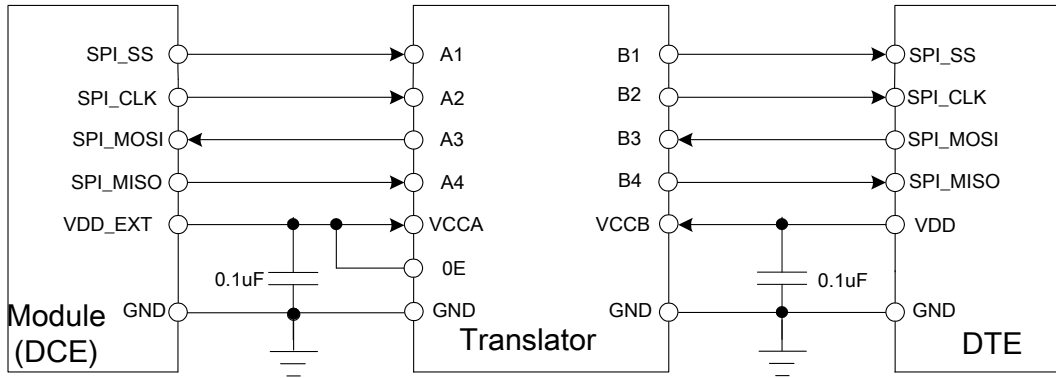

Figure 24: SPI interface level conversion reference circuit

NOTE

This function is not supported in the standard firmware. If customer wants this function, the firmware must be customized. Please contact SIMCom for more details.

SIMCom.com
Confidential

4. RF Specifications

4.1 LTE RF Specifications

Table 23: Conducted transmission power

Frequency	Power	Min.
LTE-FDD B1	23dBm +/-2.7dB	<-40dBm
LTE-FDD B2	23dBm +/-2.7dB	<-40dBm
LTE-FDD B3	23dBm +/-2.7dB	<-40dBm
LTE-FDD B4	23dBm +/-2.7dB	<-40dBm
LTE-FDD B5	23dBm +/-2.7dB	<-40dBm
LTE-FDD B8	23dBm +/-2.7dB	<-40dBm
LTE-FDD B12	23dBm +/-2.7dB	<-40dBm
LTE-FDD B13	23dBm +/-2.7dB	<-40dBm
LTE-FDD B17	23dBm +/-2.7dB	<-40dBm
LTE-FDD B18	23dBm +/-2.7dB	<-40dBm
LTE-FDD B19	23dBm +/-2.7dB	<-40dBm
LTE-FDD B20	23dBm +/-2.7dB	<-40dBm
LTE-FDD B25	23dBm +/-2.7dB	<-40dBm
LTE-FDD B26	23dBm +/-2.7dB	<-40dBm
LTE-FDD B28	23dBm +/-2.7dB	<-40dBm
LTE-FDD B66	23dBm +/-2.7dB	<-40dBm
LTE-FDD B70	23dBm +/-2.7dB	<-40dBm
LTE-FDD B71	23dBm +/-2.7dB	<-40dBm
LTE-FDD B85	23dBm +/-2.7dB	<-40dBm

NOTE

The max power is tested result single-tone in CAT-NB2. Multi-tone test results please refer to part 6.2.3F.3 for CAT-NB2.

Table 24: Maximum Power Reduction (MPR) for UE category NB2 Power Class 3

Modulation	QPSK		
Tone positions for 3 Tones allocation	0-2	3-5 and 6-8	9-11
MPR	≤ 0.5 dB	0 dB	≤ 0.5 dB
Tone positions for 6 Tones allocation	0-5 and 6-11		
MPR	≤ 1 dB	≤ 1 dB	
Tone positions for 12 Tones allocation	0-11		
MPR	≤ 2 dB		

Table 25: E-UTRA operating bands

E-UTRA	UL Freq.	DL Freq.	Duplex Mode
1	1920~1980 MHz	2110~2170 MHz	HD-FDD
2	1850~1910MHz	1930~1990MHz	HD-FDD
3	1710~1785 MHz	1805~1880 MHz	HD-FDD
4	1710~1755MHz	2110~2155MHz	HD-FDD
5	824~849 MHz	869~894 MHz	HD-FDD
8	880~915 MHz	925~960 MHz	HD-FDD
12	699~716 MHz	729~746 MHz	HD-FDD
13	777~787 MHz	746~756 MHz	HD-FDD
17	704~716MHz	734~746MHz	HD-FDD
18	815~830 MHz	860~875 MHz	HD-FDD
19	830~845 MHz	875~890 MHz	HD-FDD
20	832~862 MHz	791~821 MHz	HD-FDD
25	1850~1915MHz	1930~1995MHz	HD-FDD
26	814~849 MHz	859~894 MHz	HD-FDD
28	703~748 MHz	758~803 MHz	HD-FDD
66	1710~1780MHz	2110~2200MHz	HD-FDD
70	1695~1710MHz	1995~2020MHz	HD-FDD
71	663~698MHz	617~652MHz	HD-FDD
85	698~716 MHz	728~746MHz	HD-FDD

Table 26: CAT-NB2 Reference sensitivity (QPSK)

Operating band	SensitivitydBm (95% throughput 3GPP required)	SensitivitydBm (95% throughput without repetitions)	SensitivitydBm (95% throughput with repetitions)
1,2,3,4,5,8,12,13,17,18,19,20,25,26,28,66,70,71,85	-108.2	-114	-131

4.2 LTE Antenna Design Guide

Users should connect antennas to SIM7020G’s antenna pads through micro-strip line or other types of RF trace and the trace impedance must be controlled in 50Ω. SIMCom recommends that the total insertion loss between the antenna pads and antennas should meet the following requirements:

Table 27: Trace loss

Frequency	Loss
700MHz-960MHz	<0.5dB
1710MHz-2170MHz	<0.9dB
2300MHz-2650MHz	<1.2dB

To facilitate the antenna tuning and certification test, a RF connector and an antenna matching circuit should be added. The following figure is the recommended circuit.

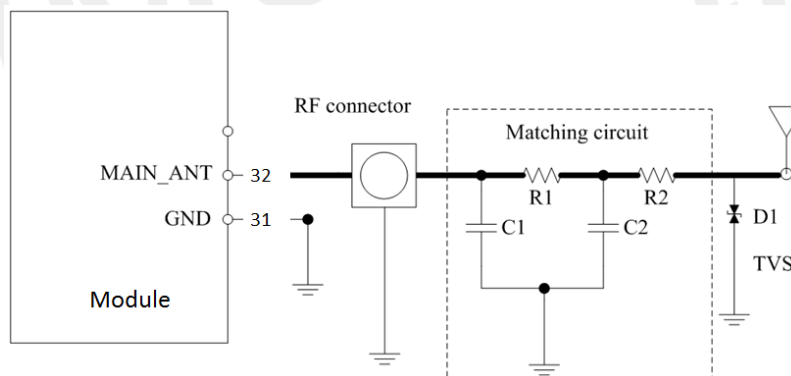

Figure 25: Antenna matching circuit (MAIN_ANT)

In above figure, the components R1, C1, C2 and R2 are used for antenna matching, the values of components can only be achieved after the antenna tuning and usually provided by antenna vendor. By default, the R1, R2 are 0Ω resistors, and the C1, C2 are reserved for tuning. The component D1 is a TVS for ESD protection, and it is optional for users according to application environment.

The RF test connector is used for the conducted RF performance test, and should be placed as close as to the module’s MAIN_ANT pin. The traces impedance between SIM7020G and antenna must be controlled in 50Ω.

Two TVS are recommended in the table below.

Table 28: Recommended TVS

Package	Part Number	Vender
0201	LXES03AAA1-154	Murata
0402	LXES15AAA1-153	Murata

4.3 RF traces note

4.3.1 RF traces layout

Keep the RF trace from module ant pin to antenna as short as possible

RF trace should be $50\ \Omega$ either on the top layer or in the inner layer

RF trace should be avoided right angle and sharp angle.

Put enough GND vias around RF traces.

RF trace should be far away from other high speed signal lines.

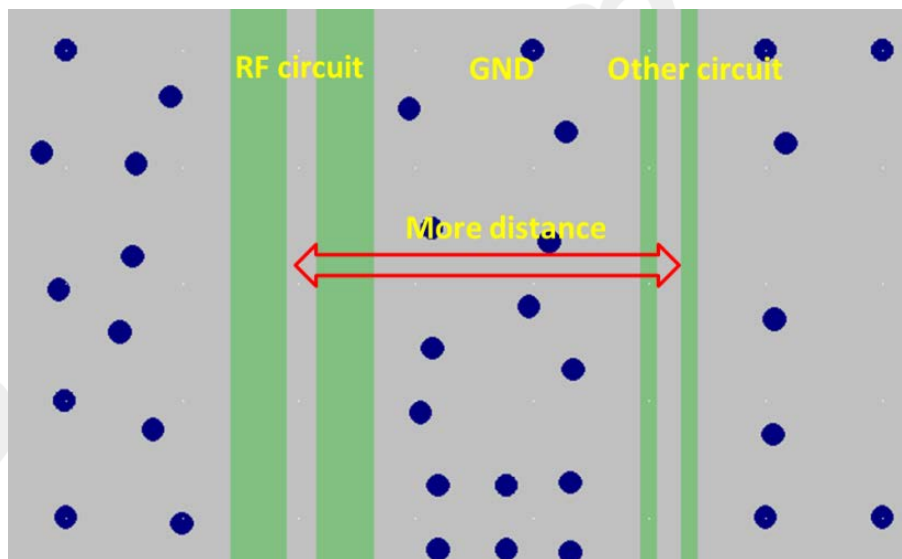

Figure 26: RF trace should be far away from other high speed signal lines

Avoiding the paroling rout of other system antennas nearby.

There should be some distance from The GND to the inner conductor of the SMA connector. It is better to keep out all the layers from inner to the outer conductor.

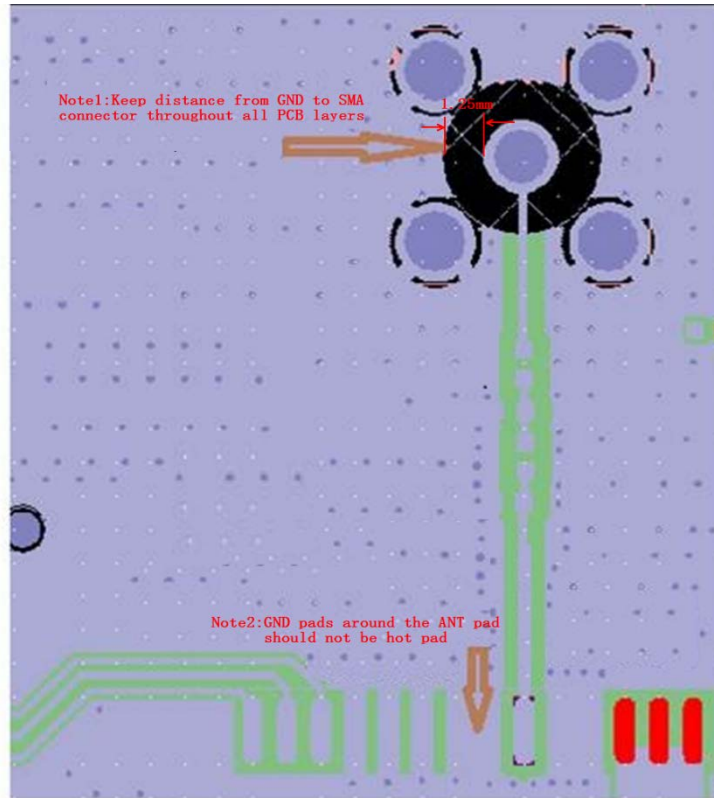

Figure 27: The distance between GND to the inner conductor of SMA

GND pads around the ANT pad should not be hot pad to keep the GND complete, as shown in fig.27 Note2.

NOTE

1. Keep distance from GND to SMA connector throughout all PCB layers;
2. GND pads around the ANT pad should not be hot pad;

4.3.2 LTE ANT and other system ANT decoupling

Make sure the efficiency of LTE main ANT more than 40%

Keep the decoupling of LTE main ANT to WLAN ANT more than 15dB

Keep the decoupling of LTE main ANT to GNSS ANT more than 30dB

NOTE

The decoupling value can be provided by ANT adventure. More details can refer to the document[25].

5. Electrical Specifications

5.1 Absolute maximum ratings

Absolute maximum rating for digital and analog pins of SIM7020G are listed in the following table:

Table 29: Absolute maximum ratings

Parameter	Min.	Typ.	Max.	Unit
Voltage at VBAT	-0.3	-	3.63	V
Voltage at USB_VBUS	-0.3	-	5.50	V
Voltage at digital pins (GPIO, UART etc)	-0.3	-	3.63	V
Voltage at digital pins (SIM)	-0.3	-	3.63	V
Voltage at PWRKEY/RESET/RTC_EINT/RTC_GPIO0	-0.3	-	3.63	V

5.2 Operating conditions

Table 30: Recommended operating ratings

Parameter	Min.	Typ.	Max.	Unit
Voltage at VBAT	2.10	3.30	3.60	V
Voltage at USB_VBUS	2.50	5.0	5.25	V

Table 31: 1.8V Digital I/O characteristics*

Parameter	Description	Min.	Typ.	Max.	Unit
V _{IH}	High-level input voltage	1.17	1.8	2.1	V
V _{IL}	Low-level input voltage	-0.3	0	0.63	V
V _{OH}	High-level output voltage	1.35	-	1.8	V
V _{OL}	Low-level output voltage	0	-	0.45	V
I _{OH}	High-level output current (no pull down resistor)			4	mA
I _{OL}	Low-level output current (no pull up resistor)			4	mA

I_{IH}	Input high leakage current (no pull down resistor)			5	uA
I_{IL}	Input low leakage current(no pull up resistor)			5	uA

NOTE

These parameters are for digital interface pins, such asGPIOs (including NETLIGHT, STATUS, SIM_DET), UART.

The operating temperature of SIM7020G is listed in the following table.

Table 32: Operating temperature

Parameter	Min.	Typ.	Max.	Unit
Normal operation temperature	-30	25	80	°C
Extended operation temperature*	-40	25	85	°C
Storage temperature	-45	25	90	°C

NOTE

The performance will be reduced slightly from the 3GPP specifications if the temperature is outside the normal operating temperature range and still within the extreme operating temperature range.

5.3 Operating Mode

5.3.1 Operating Mode Definition

The table below summarizes the various operating modes of SIM7020G product.

Table 33: Operating mode Definition

Mode		Function
Normal operation	Sleep mode	In this case, the current consumption of module will be reduced to the minimal level and the module can still receive paging message and SMS.
	Idle mode	Software is active. Module is registered to the network, and the module is ready to communicate.
	Standby mode	Module is ready for data transmission, but no data is currently sent or received. In this case, power consumption depends on network settings.
	Data transmission mode	There is data transmission in progress. In this case, power consumption is related to network settings (e.g. power control level); uplink/downlink data rates, etc.
Minimum functionality mode		AT command "AT+CFUN=0" AT+CSCLK=1 can be used to set the module to a minimum functionality mode without removing the power supply. In this mode, the RF part of the module will not work and the SIM card will not be accessible, but the serial port and USB port are NOT accessible. The power consumption in this mode is lower than normal mode.
Flight mode		AT command "AT+CFUN=4" can be used to set the module to flight mode without removing the power supply. In this mode, the RF part of the module will not work, but the serial port and USB port are still accessible. The power consumption in this mode is lower than normal mode.
PSM mode		In this mode, the module will be the least current consumption. Meanwhile, all the output of the LDO and DCDC in the module will be closed except the RTC power. And also all of the functions will be unavailable except the RTC function. In PSM, RTC_GPIO0 will change state from high to low. RTC_EINT or PWRKEY can wake up the module.
Power off mode		Module will go into power off mode by sending the AT command "AT+CPOWD=1" or pull down the PWRKEY pin, normally. In this mode the power management unit shuts down the power supply, and software is not active. The serial port and USB are is not accessible.

5.3.2 Sleep mode

In sleep mode, the current consumption of module will be reduced to the minimal level, and module can still receive paging message and SMS.

Several hardware and software conditions must be satisfied together in order to let SIM7020G enter sleep mode:

- USB condition: Connected USB can't enter into sleep mode. So if module wants to enter into sleep mode, it must disconnect the power supply for USB_VBUS first.
- Software condition: If module wants to enter into sleep mode, AT comment "AT+CSCLK=1" must be set to close some clock in the module. If the value "AT+CSCLK" is "0", module will never enter into sleep mode.
- UART condition: If module wants to enter into sleep mode, AT comment "AT+CSCLK=1" must be set to close some clock in the module. If the value "AT+CSCLK" is "0", module will never enter into sleep mode.

5.3.3 Minimum functionality mode and Flight mode

Minimum functionality mode ceases a majority function of the module, thus minimizing the power consumption. This mode is set by the AT command which provides a choice of the functionality levels.

AT+CFUN=0: Minimum functionality

AT+CFUN=1: Full functionality (Default)

AT+CFUN=4: Flight mode

If SIM7020G has been set to minimum functionality mode, the RF function and SIM card function will be closed. In this case, the serial port and USB are NOT accessible, but RF function and SIM card will be unavailable.

If SIM7020G has been set to flight mode, the RF function will be closed. In this case, the serial port and USB are still accessible, but RF function will be unavailable.

When SIM7020G is in minimum functionality or flight mode, it can return to full functionality by the AT command "AT+CFUN=1".

5.3.4 Power Saving Mode (PSM)

SIM7020G module can enter into PSM for reducing its power consumption. The mode is similar to power-off, but the module remains registered on the network and there is no need to re-attach or re-establish the network connections. So in PSM all the functions will be unavailable except the RTC function, module cannot immediately respond users' requests.

In PSM, RTC_GPIO0 will change state from low to high if RTC_EINT receive interrupt event.

Either of the following methods will wake up the module from PSM:

- Pulling PWRKEY or RTC_EINT to low level will wake up the module.
- When T3412 timer expires, the module will be automatically woken up.

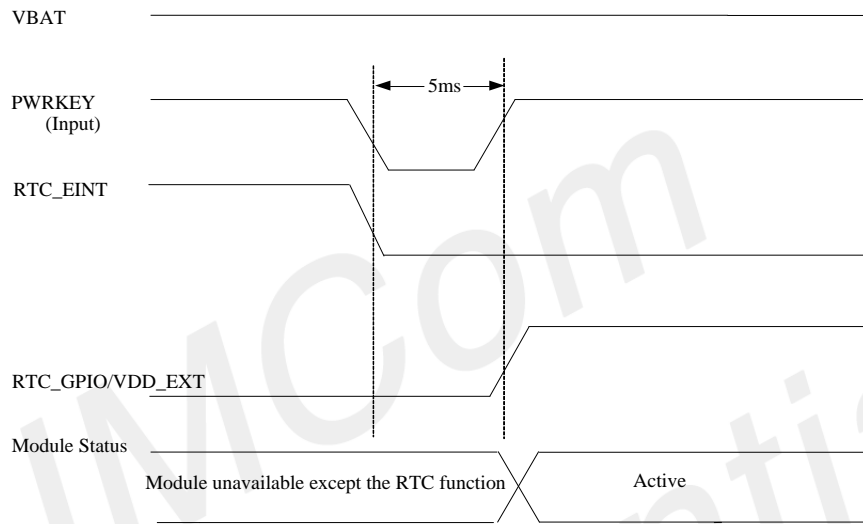

Figure 28: PWRKEY or RTC_EINTwake up PSM sequence

NOTE

Power domain of RTC_GPIO0 and RTC_EINT is VBATdomain, please consider the electrical characteristics when connecting to external IO (suggest to use trigger as low-active).

Table 34: RTC_GPIO0/RTC_EINT characteristics

IO	Vih(min).	Vih(max).	Vil(min).	Vil(max).	VBAT
RTC_EINT	1.575	2.1	0	0.525	2.1(min)
RTC_EINT	2.725	3.6	0	0.905	3.6(max)
IO	Voh(min).	Voh(max).	Vol(min).	Vol(max).	VBAT
RTC_GPIO0	1.785	-	-	0.315	2.1(min)
RTC_GPIO0	3.085	-	-	0.545	3.6(max)

5.3.5 Extended Mode DRX (e-DRX)

In idle or sleep mode, module and the network may negotiate over non-access stratum signaling the use of extended mode DRX for reducing power consumption.

5.4 Current Consumption

The current consumption is listed in the table below.

Table 35: Current consumption on VBAT Pins (VBAT=3.3V)

Sleep/Idle Mode	
LTE supply current (without USB connection)	Sleep mode Typical: 236uA (at+cfun=0) Idle mode Typical: 5.6mA
Power Saving Mode	
PSM supply current	PSM mode Typical: 3.4uA
eDRX	
eDRX mode supply current (Tested in sleep mode)	@PTW=10.24s, eDRX=20.48s, DRX=1.28s Typical : 230uA
	@PTW=10.24s, eDRX=20.48s, DRX=2.56s Typical : 130uA
	@PTW=20.48s, eDRX=81.92s, DRX=2.56s Typical : 95uA
	@PTW=20.48s, eDRX=162.84s, DRX=2.56s Typical: 77.5uA
	@PTW=40.96s, eDRX=655.36s, DRX=2.56s Typical: 69uA
LTE data	
LTE-FDD B1	@23dbm Typical: 90.61mA @10dbm Typical: 24.35mA @0dbm Typical: 21.73mA
LTE-FDD B2	@23dbm Typical: 90.34mA @10dbm Typical: 24.87mA @0dbm Typical: 21.50 mA
LTE-FDD B3	@23dbm Typical: 120.24mA @10dbm Typical: 26.80mA @0dbm Typical: 22.71mA
LTE-FDD B4	@23dbm Typical: 117.56mA @10dbm Typical: 26.46mA @0dbm Typical: 22.81mA
LTE-FDD B5	@23dbm Typical: 107.06mA @10dbm Typical: 25.43mA @0dbm Typical: 21.14mA
LTE-FDD B8	@23dbm Typical: 112.57mA @10dbm Typical: 26.02mA @0dbm Typical: 21.22mA
LTE-FDD B12	@23dbm Typical: 89.29mA @10dbm Typical: 24.15mA @0dbm Typical: 20.69mA

LTE-FDD B13	@23dbm Typical: 99.38mA @10dbm Typical: 29.37mA @0dbm Typical: 24.99 mA
LTE-FDD B17	@23dbm Typical: 88.51mA @10dbm Typical: 24.16mA @0dbm Typical: 20.67mA
LTE-FDD B18	@23dbm Typical: 103.93mA @10dbm Typical:25.18mA @0dbm Typical: 20.98mA
LTE-FDD B19	@23dbm Typical: 107.19mA @10dbm Typical: 25.25mA @0dbm Typical: 21.01mA
LTE-FDD B20	@23dbm Typical: 109.97mA @10dbm Typical: 25.45mA @0dbm Typical: 21.09mA
LTE-FDD B25	@23dbm Typical: 90.89mA @10dbm Typical: 24.96mA @0dbm Typical: 21.62 mA
LTE-FDD B26	@23dbm Typical: 101.73mA @10dbm Typical: 25.15mA @0dbm Typical: 21.04mA
LTE-FDD B28	@23dbm Typical: 90.04mA @10dbm Typical:24.41mA @0dbm Typical: 20.74mA
LTE-FDD B66	@23dbm Typical: 118.61mA @10dbm Typical: 26.82mA @0dbm Typical: 22.92mA
LTE-FDD B70	@23dbm Typical: 137.69mA @10dbm Typical: 28.35mA @0dbm Typical: 23.74mA
LTE-FDD B70	@23dbm Typical: 137.69mA @10dbm Typical: 28.35mA @0dbm Typical: 23.74mA
LTE-FDD B71	@23dbm Typical: 93.13mA @10dbm Typical:24.25mA @0dbm Typical: 21.68mA
LTE-FDD B85	@23dbm Typical: 93.31mA @10dbm Typical:27.36mA @0dbm Typical: 20.44mA

5.5 ESD Notes

SIM7020G is sensitive to ESD in the process of storage, transporting, and assembling. When SIM7020G is mounted on the users' mother board, the ESD components should be placed beside the connectors which human body may touch, such as SIM card holder, audio jacks, switches, keys, etc. The following table shows the SIM7020G ESD measurement performance without any external ESD component.

Table 36: The ESD performance measurement table

Part	Contact discharge(kV)	Air discharge(kV)
GND (Shield)	+/-6	+/-12
GND (RF)	+/-6	+/-12
VBAT	+/-5	+/-10
Antenna port	+/-5	+/-10
Other PADs	+/-3	+/-6

NOTE

Temperature: 25°C, Humidity: 45%, tested on SIMCOM-EVB.

6.SMT Production Guide

6.1 Top and Bottom View of SIM7020G

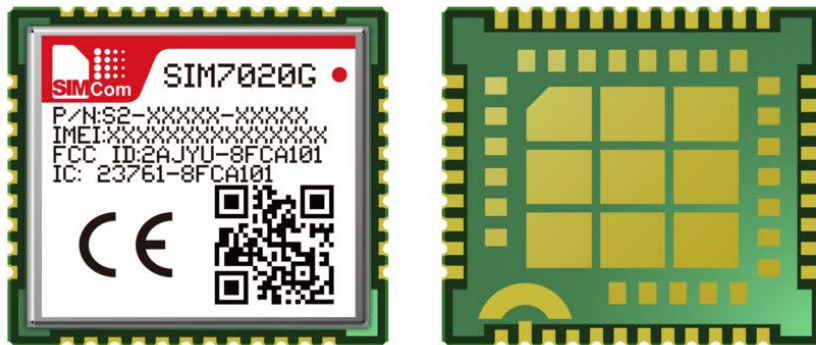

Figure 29: Top and bottom view of SIM7020G

6.2 Typical SMT Reflow Profile

SIMCom provides a typical soldering profile. Therefore the soldering profile shown below is only a generic recommendation and should be adjusted to the specific application and manufacturing constraints.

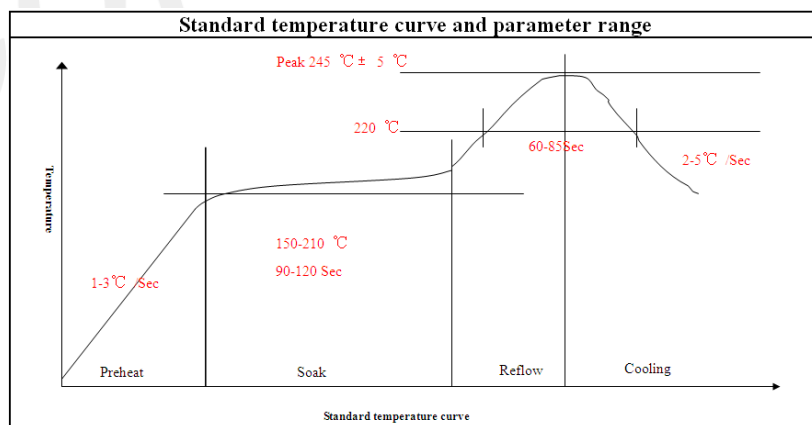

Figure 30: The ramp-soak-spike reflow profile of SIM7020G

NOTE

For more details about secondary SMT, please refer to the document [21].

6.3 Moisture Sensitivity Level (MSL)

SIM7020G is qualified to Moisture Sensitivity Level (MSL) **3** in accordance with JEDEC J-STD-033. If the prescribed time limit is exceeded, users should bake modules for 192 hours in drying equipment (<5% RH) at 40+5/-0°C, or 72 hours at 85+5/-5°C. Note that plastic tray is not heat-resistant, and only can be baked at 45° C.

Table 37: Moisture Sensitivity Level and Floor Life

Moisture Sensitivity Level (MSL)	Floor Life (out of bag) at factory ambient $\leq 30^{\circ}\text{C}/60\% \text{RH}$ or as stated
1	Unlimited at $\leq 30^{\circ}\text{C}/85\% \text{RH}$
2	1 year
2a	4 weeks
3	168 hours
4	72 hours
5	48 hours
5a	24 hours
6	Mandatory bake before use. After bake, it must be reflowed within the time limit specified on the label.

NOTE

IPC / JEDEC J-STD-033 standard must be followed for production and storage.

6.4 Baking Requirements

SIM7020G modules are vacuum packaged, and guaranteed for 6 months storage without opening or leakage under the following conditions: the environment temperature is lower than 40°C, and the air humidity is less than 90%.

If the condition meets one of the following ones shown below, the modules should be baked sufficiently before re-flow soldering, and the baking condition is shown in table below; otherwise the module will be at the risk of permanent damage during re-flow soldering.

If the vacuum package is broken or leakage;

If the vacuum package is opened after 6 months since it's been packed;

If the vacuum package is opened within 6 months but out of its Floor Life at factory ambient $\leq 30^{\circ}\text{C}/60\%\text{RH}$ or as stated.

Table 38: Baking requirements

Baking temperature	Moisture	Time
40°C±5°C	<5%	192 hours
120°C±5°C	<5%	4 hours

NOTE

Care should be taken if that plastic tray is not heat-resistant, the modules should be taken out for preheating, and otherwise the tray may be damaged by high-temperature heating.

7. Packaging

SIM7020G module support tray packaging (default packaging).

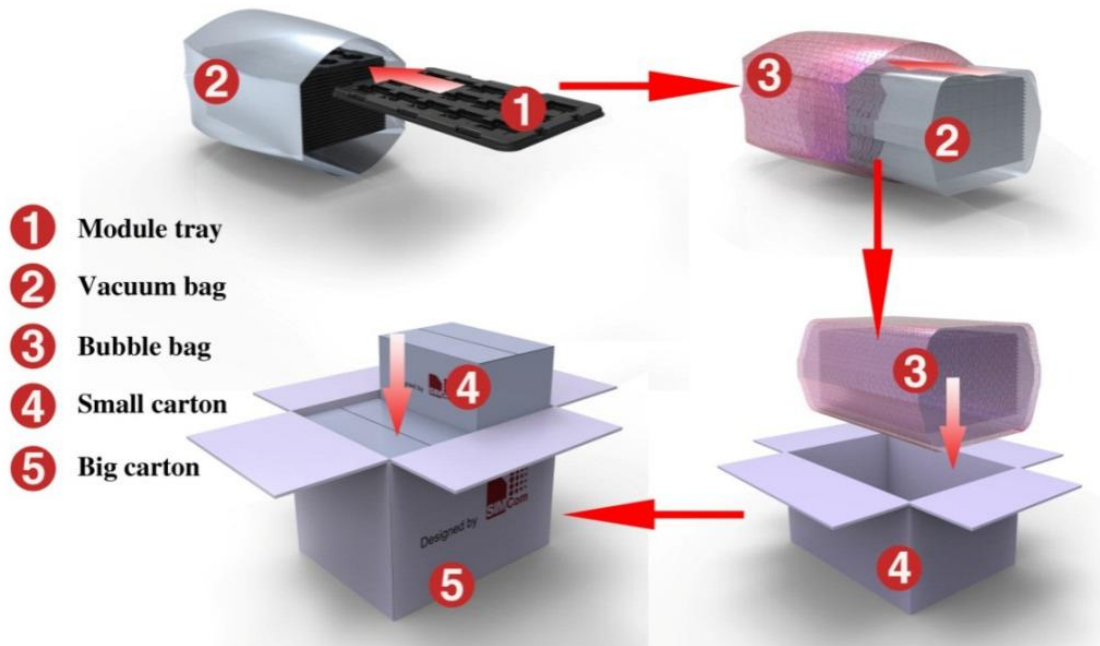

Figure 31: packaging diagram

Module tray drawing:

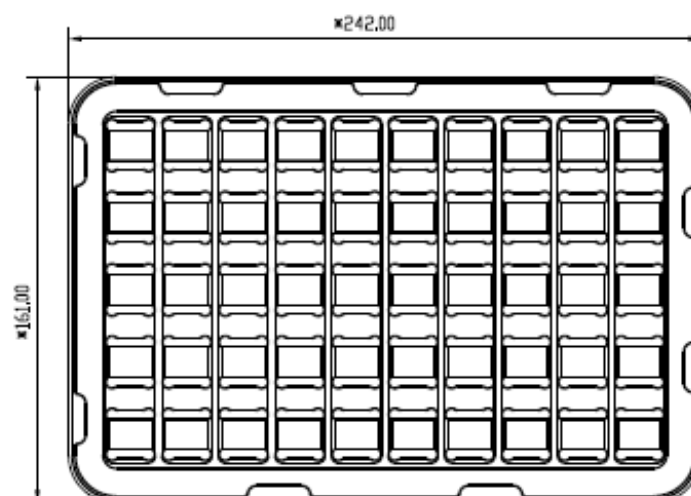

Figure 32: Tray drawing

Table 39: Tray size

Length ($\pm 3\text{mm}$)	Width ($\pm 3\text{mm}$)	Module number
242.0	161.0	50

Small carton drawing:

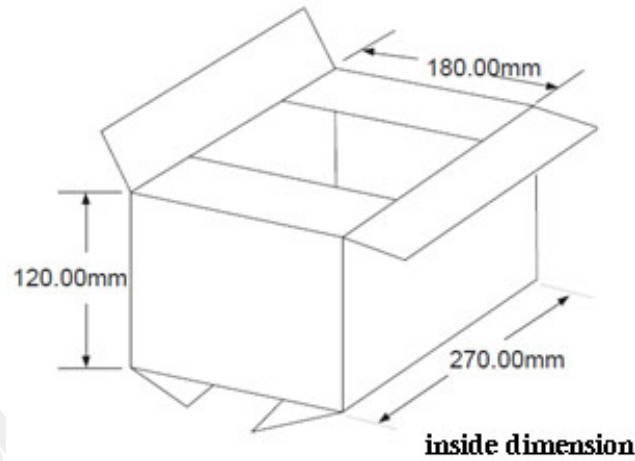

Figure 33: Small carton drawing

Table 40: Small Carton size

Length ($\pm 10\text{mm}$)	Width ($\pm 10\text{mm}$)	Height ($\pm 10\text{mm}$)	Module number
270	180	120	50*20=1000

Big carton drawing:

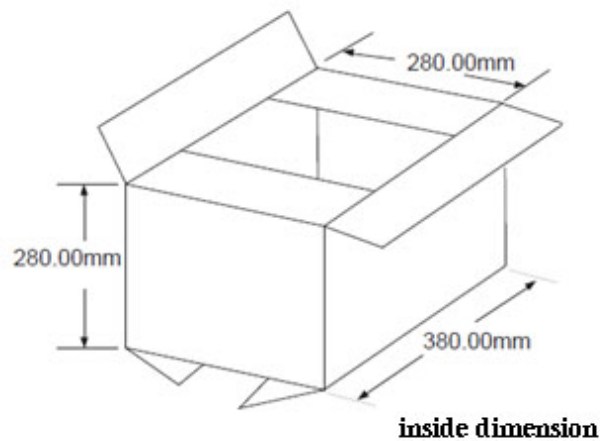

Figure 34: Big carton drawing

Table 41: Big Carton size

Length (±10mm)	Width (±10mm)	Height (±10mm)	Module number
380	280	280	1000*4=4000

SIMCom
Confidential

8. Appendix

8.1 Related Documents

Table 42: Related Documents

NO.	Title	Description
[1]	SIM7020 Series_AT Command Manual_V1.xx	AT Command Manual
[2]	GSM 07.07	Digital cellular telecommunications (Phase 2+); AT command set for GSM Mobile Equipment (ME)
[3]	GSM 07.10	Support GSM 07.10 multiplexing protocol
[4]	GSM 07.05	Digital cellular telecommunications (Phase 2+); Use of Data Terminal Equipment – Data Circuit terminating Equipment (DTE – DCE) interface for Short Message Service (SMS) and Cell Broadcast Service (CBS)
[5]	GSM 11.14	Digital cellular telecommunications system (Phase 2+); Specification of the SIM Application Toolkit for the Subscriber Identity Module – Mobile Equipment (SIM – ME) interface
[6]	GSM 11.11	Digital cellular telecommunications system (Phase 2+); Specification of the Subscriber Identity Module – Mobile Equipment (SIM – ME) interface
[7]	GSM 03.38	Digital cellular telecommunications system (Phase 2+); Alphabets and language-specific information
[8]	GSM 11.10	Digital cellular telecommunications system (Phase 2) ; Mobile Station (MS) conformance specification; Part 1: Conformance specification
[9]	3GPP TS 51.010-1	Digital cellular telecommunications system (Release 5); Mobile Station (MS) conformance specification
[10]	3GPP TS 34.124	Electromagnetic Compatibility (EMC) for mobile terminals and ancillary equipment.
[11]	3GPP TS 34.121	Electromagnetic Compatibility (EMC) for mobile terminals and ancillary equipment.
[12]	3GPP TS 34.123-1	Technical Specification Group Radio Access Network; Terminal conformance specification; Radio transmission and reception (FDD)
[13]	3GPP TS 34.123-3	User Equipment (UE) conformance specification; Part 3: Abstract Test Suites.
[14]	EN 301 908-02 V2.2.1	Electromagnetic compatibility and Radio spectrum Matters (ERM); Base Stations (BS) and User Equipment (UE) for IMT-2000. Third Generation cellular networks; Part 2: Harmonized EN for IMT-2000, CDMA Direct Spread (UTRA FDD) (UE) covering essential requirements of article 3.2 of the R&TTE Directive
[15]	EN 301 489-24 V1.2.1	Electromagnetic compatibility and Radio Spectrum Matters (ERM); Electromagnetic Compatibility (EMC) standard for radio equipment and services; Part 24: Specific conditions for

		IMT-2000 CDMA Direct Spread (UTRA) for Mobile and portable (UE) radio and ancillary equipment
[16]	IEC/EN60950-1(2001)	Safety of information technology equipment (2000)
[17]	3GPP TS 51.010-1	Digital cellular telecommunications system (Release 5); Mobile Station (MS) conformance specification
[18]	GCF-CC V3.23.1	Global Certification Forum - Certification Criteria
[19]	2002/95/EC	Directive of the European Parliament and of the Council of 27 January 2003 on the restriction of the use of certain hazardous substances in electrical and electronic equipment (RoHS)
[20]	Module secondary-SMT-UGD-V1.xx	Module secondary SMT Guidelines
[21]	SIM7X00 Series_UART_Application Note_V1.xx	This document describes how to use UART interface of SIMCom modules.
[22]	ETSI EN 301 908-13 (ETSI TS 136521-1 R13.4.0)	IMT cellular networks; Harmonized EN covering the essential requirements of article 3.2 of the R&TTE Directive; Part 13
[23]	Antenna design guidelines for diversity receiver system	Antenna design guidelines for diversity receiver system
[24]	SIM7020 Series_Low Power Mode_Application Note_V1.xx	Sleep Mode Application Note

SIMCom Confidential

8.2 Terms and Abbreviations







Table 43: Terms and Abbreviations

Abbreviation	Description
ADC	Analog-to-Digital Converter
ARP	Antenna Reference Point
BER	Bit Error Rate
BD	BeiDou
BTS	Base Transceiver Station
CS	Coding Scheme
CSD	Circuit Switched Data
CTS	Clear to Send
DAC	Digital-to-Analog Converter
DRX	Discontinuous Reception
DSP	Digital Signal Processor
DTE	Data Terminal Equipment (typically computer, terminal, printer)
DTR	Data Terminal Ready
DTX	Discontinuous Transmission
EFR	Enhanced Full Rate
EGSM	Enhanced GSM
EMC	Electromagnetic Compatibility
ESD	Electrostatic Discharge
ETS	European Telecommunication Standard
EVDO	Evolution Data Only
FCC	Federal Communications Commission (U.S.)
FD	SIM fix dialing phonebook
FDMA	Frequency Division Multiple Access
FR	Full Rate
GMSK	Gaussian Minimum Shift Keying
GNSS	Global Navigation Satellite System
GPRS	General Packet Radio Service
GPS	Global Positioning System
GSM	Global Standard for Mobile Communications
HR	Half Rate
HSPA	High Speed Packet Access
I2C	Inter-Integrated Circuit
IMEI	International Mobile Equipment Identity
LTE	Long Term Evolution
MO	Mobile Originated
MS	Mobile Station (GSM engine), also referred to as TE

MT	Mobile Terminated
NMEA	National Marine Electronics Association
PAP	Password Authentication Protocol
PBCCH	Packet Switched Broadcast Control Channel
PCB	Printed Circuit Board
PCS	Personal Communication System, also referred to as GSM 1900
RF	Radio Frequency
RMS	Root Mean Square (value)
RTC	Real Time Clock
SIM	Subscriber Identification Module
SMS	Short Message Service
SMPS	Switched-mode power supply
TDMA	Time Division Multiple Access
TE	Terminal Equipment, also referred to as DTE
TX	Transmit Direction
UART	Universal Asynchronous Receiver & Transmitter
VSWR	Voltage Standing Wave Ratio
SM	SIM phonebook
NC	Not connect
EDGE	Enhanced data rates for GSM evolution
HSDPA	High Speed Downlink Packet Access
HSUPA	High Speed Uplink Packet Access
ZIF	Zero intermediate frequency
WCDMA	Wideband Code Division Multiple Access
VCTCXO	Voltage control temperature-compensated crystal oscillator
SIM	Universal subscriber identity module
UMTS	Universal mobile telecommunications system
UART	Universal asynchronous receiver transmitter
PSM	Power save mode

8.3 Safety Caution

Table 44: Safety Caution

Marks	Requirements
	<p>When in a hospital or other health care facility, observe the restrictions about the use of mobiles. Switch the cellular terminal or mobile off, medical equipment may be sensitive and not operate normally due to RF energy interference.</p>
	<p>Switch off the cellular terminal or mobile before boarding an aircraft. Make sure it is switched off. The operation of wireless appliances in an aircraft is forbidden to prevent interference with communication systems. Forgetting to think much of these instructions may impact the flight safety, or offend local legal action, or both.</p>
	<p>Do not operate the cellular terminal or mobile in the presence of flammable gases or fumes. Switch off the cellular terminal when you are near petrol stations, fuel depots, chemical plants or where blasting operations are in progress. Operation of any electrical equipment in potentially explosive atmospheres can constitute a safety hazard.</p>
	<p>Your cellular terminal or mobile receives and transmits radio frequency energy while switched on. RF interference can occur if it is used close to TV sets, radios, computers or other electric equipment.</p>
	<p>Road safety comes first! Do not use a hand-held cellular terminal or mobile when driving a vehicle, unless it is securely mounted in a holder for hands free operation. Before making a call with a hand-held terminal or mobile, park the vehicle.</p>
	<p>GSM cellular terminals or mobiles operate over radio frequency signals and cellular networks and cannot be guaranteed to connect in all conditions, especially with a mobile fee or an invalid SIM card. While you are in this condition and need emergent help, please remember to use emergency calls. In order to make or receive calls, the cellular terminal or mobile must be switched on and in a service area with adequate cellular signal strength.</p> <p>Some networks do not allow for emergency call if certain network services or phone features are in use (e.g. lock functions, fixed dialing etc.). You may have to deactivate those features before you can make an emergency call.</p> <p>Also, some networks require that a valid SIM card be properly inserted in the cellular terminal or mobile.</p>